



—  
your partner  
in sensor  
technology.

# + User Manual EE160

Humidity and Temperature Sensor  
for Building Automation



# Content

<b>1</b>	<b>General Information</b>	<b>3</b>
1.1	Explanation of Warning Notices and Symbols	3
1.2	Safety Instructions	4
1.2.1.	General Safety Instructions	4
1.2.2.	Intended Use	4
1.2.3.	Mounting, Start-up and Operation	4
1.3	Environmental Aspects	5
1.4	ESD Protection	5
<b>2</b>	<b>Scope of Supply</b>	<b>5</b>
<b>3</b>	<b>Product Description</b>	<b>6</b>
3.1	General	6
3.2	Dimensions	6
3.3	Electrical Connection	7
3.4	Display	8
<b>4</b>	<b>Mounting and Installation</b>	<b>9</b>
<b>5</b>	<b>Setup and Configuration</b>	<b>9</b>
5.1	Product Configuration of the EE160 with new Sensing Element	9
5.1.1.	EE160 Configuration using HA011070	10
5.1.2.	EE160-M1TxJ3 (Digital Interface) Configuration Using HA011066 (not Intended for New Designs)	10
5.2	Product Configuration Adapter and Software for EE160 with New Sensing Element and Legacy Configuration Adapter HA011069 (not Intended for New Designs)	11
5.2.1.	EE160-MxTxA3 (Analogue Output, Voltage Version) with HA011069	12
5.2.2.	EE160-MxTxA6 (Analogue Output, Current Version) with HA011069 (not Intended for New Designs)	12
5.3	Product Configuration Adapter and Software for EE160 with Legacy Sensing Element	13
5.3.1.	EE160-MxTxAx (Analogue Output)	14
5.3.2.	EE160-M1TxJ3 (Digital Interface)	14
5.4	PCS10 Product Configuration Software	16
5.5	RS485 Digital Interface	16
5.5.1.	Hardware Bus Termination	16
5.5.2.	Device Address	16
5.5.3.	RS485 Digital Interface with Modbus RTU Protocol	16
5.5.4.	Modbus Register Map	18
5.5.5.	Modbus RTU Example	18
<b>6</b>	<b>Maintenance and Service</b>	<b>19</b>
6.1	Calibration and Adjustment	19
6.2	RH and T Adjustment and Calibration	19
6.3	Cleaning the Sensing Head and Filter Cap Replacement	20
6.4	Display Exchange	20
6.5	Repairs	20
<b>7</b>	<b>Accessories</b>	<b>21</b>
<b>8</b>	<b>Technical Data</b>	<b>21</b>
<b>9</b>	<b>Conformity</b>	<b>23</b>
9.1	Declarations of Conformity	23
9.2	Electromagnetic Compatibility	23
9.3	FCC Part 15 Compliance Statement	23
9.4	ICES-003 Compliance Statement	23

# 1 General Information

This user manual is intended to ensure proper handling and optimal functioning of the device. The user manual shall be read before commissioning the equipment and it shall be provided to all staff involved in transport, installation, operation, maintenance and repair. E+E Elektronik Ges.m.b.H. accepts no liability for any warranty or liability claims arising from this publication or improper handling of the product(s) described.

All information, technical data and diagrams included in this document are based on the information available at the time of writing. The document may contain technical inaccuracies and typographical errors. The contents will be revised on a regular basis and changes will be implemented in subsequent versions. The product(s) described and the contents of this document may be changed or improved at any time without prior notice.

All rights are reserved by E+E Elektronik Ges.m.b.H. No part of this document may be reproduced, published or publicly displayed in any form or by any means, nor may its contents be modified, translated, adapted, sold or disclosed to a third party without prior written permission of E+E Elektronik Ges.m.b.H.

## PLEASE NOTE

Find this document and further product information on our website at [www.epluse.com/ee160](http://www.epluse.com/ee160).

## 1.1 Explanation of Warning Notices and Symbols

### Safety precautions

Precautionary statements warn of hazards in handling the device and provide information on their prevention. The safety instruction labeling is classified by hazard severity and is divided into the following groups:

### DANGER

**Danger** indicates hazards for persons. If the safety instruction marked in this way is not followed, the hazard will very likely result in severe injury or death.

### WARNING

**Warning** indicates hazards for persons. If the safety instruction marked in this way is not followed, there is a risk of injury or death.

### CAUTION

**Caution** indicates hazards for persons. If the safety instruction marked in this way is not followed, minor or moderate injuries may occur.

### NOTICE

**Notice** signals danger to objects or data. If the notice is not observed, damage to property or data may occur.

### Informative notes

Informative notes provide important information that is characterised by its relevance.

## INFO

The information symbol indicates tips on handling the device or provides additional information on it. This information is useful to achieve optimum performance of the device.

The title field may deviate from "INFO" depending on the context. For instance, it may also read "PLEASE NOTE".

## 1.2 Safety Instructions

### 1.2.1. General Safety Instructions

#### NOTICE

Improper handling of the device may result in its damage.

- The device and mainly the filter cap shall not be exposed to unnecessary mechanical stress.
- The device must be operated with the filter cap on at all times.
- Replace the filter cap without touching the sensor elements.
- The EE160 electronics are sensitive to electrostatic discharge (ESD). Take appropriate protective measures when touching it.
- Installation, electrical connection, maintenance and commissioning shall be performed by qualified personnel only.
- Do not apply the supply voltage to the RS485 data lines.
- Use the EE160 only as intended and observe all technical specifications.

### 1.2.2. Intended Use

The EE160 is intended for the relative humidity (RH) and temperature (T) measurement in building automation.

The measured data is available on two voltage or current (2-wire) outputs, or on the RS485 interface with Modbus RTU protocol. Additionally, the EE160 features a passive T output and an optional display visualises RH and T values simultaneously.

#### WARNING

Non-compliance with the product documentation may cause safety risks for people and the entire measurement installation.

The manufacturer is not liable for any damage caused by improper handling, installation and maintenance of the device.

- Do not use the EE160 in explosive atmosphere or for measurement of aggressive gases.
- This device is not appropriate for safety, emergency stop or other critical applications where device malfunction or failure could cause injury to human beings.
- The device may not be manipulated with tools other than specifically described in this manual.

#### NOTICE

Failure to follow the instructions in this user manual may lead to measurement inaccuracy and device failures.

- The EE160 may only be operated under the conditions described in this user manual and within the specification included in chapter 8 Technical Data.
- Any unauthorised product modifications will invalidate all warranty claims. Modifications may only be carried out with express authorisation of E+E Elektronik Ges.m.b.H.!

### 1.2.3. Mounting, Start-up and Operation

The EE160 has been produced under state of the art manufacturing conditions, has been thoroughly tested and has left the factory after fulfilling all safety criteria. The manufacturer has taken all precautions to ensure safe operation of the device. The device shall be set up and installed in a way that does not impair its safe use. All applicable local and international safety guidelines for safe installation and operation of the device have to be observed. This user manual contains information and warnings that must be observed in order to ensure safe operation.

#### PLEASE NOTE

The manufacturer or his authorised agent can only be held liable in case of willful or gross negligence. In any case, the scope of liability is limited to the corresponding amount of the order issued to the manufacturer. The manufacturer assumes no liability for damage caused by non-compliance with the applicable regulations, operating instructions or the specified operating conditions. Any consequential damage is excluded from liability.

**⚠ WARNING**

Non-compliance with the product documentation may result in accidents, personal injury or property damage.

- Mounting, installation, commissioning, start-up, operation and maintenance of the device may only be carried out by qualified staff. Such staff must be authorised by the operator of the facility to carry out the mentioned activities.
- The qualified staff must have read and understood this user manual and must follow the instructions contained within. The manufacturer accepts no responsibility for non-compliance with instructions, recommendations and warnings.
- All process and electrical connections must be thoroughly checked by authorised staff before commissioning the device.
- Do not install or start-up a device suspected to be faulty. Mark it clearly as faulty and remove it from the process.
- Service operations other than described in this user manual may only be performed by the manufacturer. A faulty device may only be investigated and possibly repaired by qualified, trained and authorised staff. If the fault cannot be fixed, the device shall be removed from the process.

### 1.3 Environmental Aspects

**i PLEASE NOTE**

Products from E+E Elektronik Ges.m.b.H. are developed and manufactured in compliance with all relevant environmental protection requirements. Please observe local regulations for the disposal of the device.



For disposal, the individual components of the device must be separated according to local recycling regulations. The electronics shall be disposed of correctly as electronics waste.

### 1.4 ESD Protection



The sensing elements and the electronics board are ESD (electrostatic discharge) sensitive components of the device and must be handled as such. Failure to do so may damage the device by electrostatic discharge when touching exposed sensitive components.

## 2 Scope of Supply

Model	EE160 Wall mount (Type T1)	EE160 Duct mount (Type 2)	Additionally for all EE160 with RS485 interface
EE160 Humidity and Temperature Sensor according to order code	✓	✓	
Cable gland	✓	✓	✓
Mounting kit	✓	✓	
Mounting flange		✓	
Inspection certificate according to DIN EN 10204-3.1	✓	✓	
Quick Guide - EE160 RS485 Setup			✓

Tab. 1 Items included in the scope of supply

# 3 Product Description

## 3.1 General

The EE160 sensor is optimised for cost effective, accurate measurement of RH and T in building automation.

The measured data is available on

- Two voltage or current (2-wire) outputs
- The RS485 interface with Modbus RTU protocol
- A passive T output

Furthermore an optional display visualises RH and T values simultaneously.

Both, the wall mount and the duct mount model come with an IP65 / NEMA 4X enclosure which provides minimal installation costs and reliable protection against contamination and condensation. The encapsulated electronics in the probe and the E+E sensor coating ensure long-term stable and accurate measurements.

The user can set the RS485 interface parameters, the output scaling and perform 1- or 2-point adjustment for RH and T with an optional configuration adapter and the free PCS Product Configuration Software.

## 3.2 Dimensions

Values in mm / inch

### Type T1 wall mount

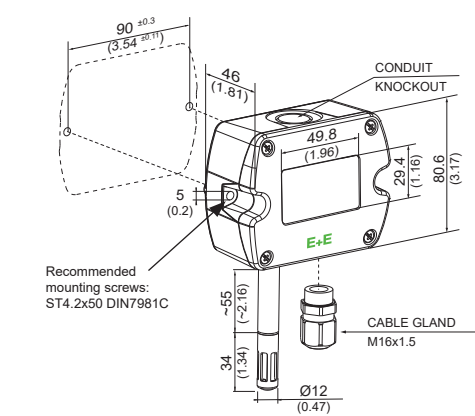

### Type T2 duct mount

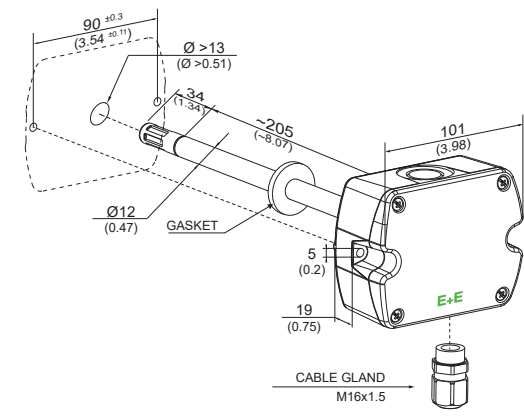

### Mounting flange

in the scope of supply for type T2

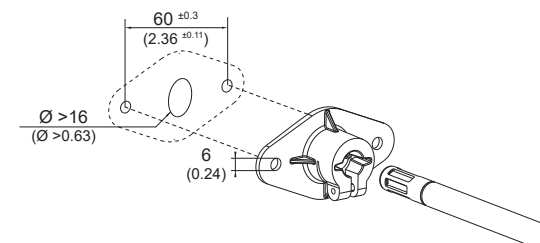

### 3.3 Electrical Connection

#### **⚠ WARNING**

Incorrect installation, wiring or power supply may cause overheating and result in personal injury or property damage.

Cables must not be under voltage during electrical installation and connection or disconnection, especially at terminal connections on circuit boards. For correct cabling, always observe the presented wiring diagram for the product version used.

The manufacturer cannot be held responsible for personal injury or damage to property caused by incorrect handling, installation, wiring, power supply or maintenance of the device.

EE160 features screw terminals for connecting the power supply and the outputs. The cables are fed into the enclosure through the M16 cable gland.

#### **NOTICE**

Ensure that the cable glands are closed tightly for the power supply and outputs cable. This is necessary to assure the IP rating of the enclosure according to the EE160 specification, as well as for stress relief at the screw terminals on the EE160 board.

#### Connection Diagram

##### EE160-M1TxJ3

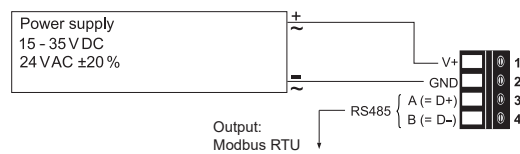
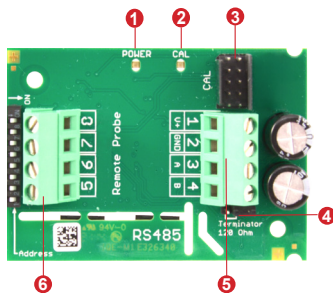

#### **i PLEASE NOTE**

##### Bus Termination:

If required, the RS485 bus termination can be realised with 120 Ω resistor, jumper on the board.

##### EE160MxTxA3

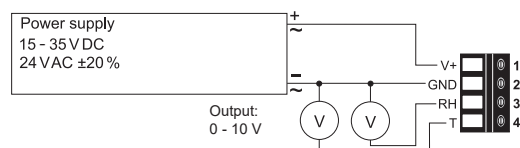
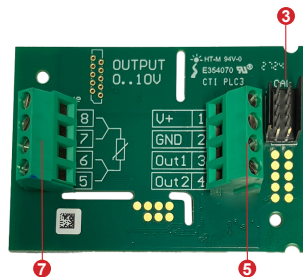

#### T-passive connection for M8TxA3

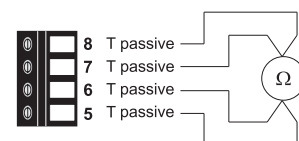



## 4 Mounting and Installation

For mounting, the cable gland (in the scope of supply) onto the EE160 enclosure use a matching wrench.

When using the EE160 with conduit connection for the North American market use a flat screwdriver to knock open the blind at the top of the enclosure, carefully. Take good care to avoid damaging the electronics inside the enclosure. The conduit adapter is not included in the scope of supply. The M16x1.5 opening for the cable gland shall be tightly closed using the blind plug included in the scope of supply (see also chapter 3.2 Dimensions).

### **i** PLEASE NOTE

For best measurement results, the EE160

- must be installed in an environment where the medium to be measured flows sufficiently around the probe.
- temperature of the sensing probe and mainly of the sensing head is the same as the temperature of the air to measure. Avoid mounting the EE160 sensor in a way which creates temperature gradients along the probe.
- shall not be placed near influencing objects such as heating radiators or fan heaters.
- self-heating effects are compensated, @24 V DC and 250  $\Omega$  load resistance for A6 versions.

## 5 Setup and Configuration

The EE160 is ready to use and does not require any further configuration. The factory setup of EE160 corresponds to the specified order code. Please refer to the data sheet at [www.epluse.com/ee160](http://www.epluse.com/ee160).

If needed, the factory setup can be modified with the help of the Product Configuration Software and the USB configuration adapter.

Besides the output scaling the user can change the communication settings for digital interface and perform one or two point adjustment for humidity and temperature. Additionally warning thresholds for RH and T display visualization can be set.

From 01/2023, the EE160 is equipped with a new sensing element. Before configuring the EE160, check which sensing element it is equipped with.

### 5.1 Product Configuration of the EE160 with new Sensing Element

Remove the filter cap and check the sensing element of your EE160.



Fig. 2 EE160 with new sensing element

If the EE160 is equipped with a new sensing element according to the picture above, it must only be configured or adjusted using the PCS10 Product Configuration Software (free download from [www.epluse.com/pcs10](http://www.epluse.com/pcs10)) and the adapters according to the following table:

Version	EE160 new sensing element	
	Configuration hardware	Configuration software
EE160-MxTxA3 Analogue voltage 0...10 V	HA011070	PCS10
EE160-MxTxA6 Analogue voltage 4...20 mA	HA011070	PCS10
EE160-M1TxJ3 Digital RS485 Modbus	HA011070 <sup>1)</sup>	PCS10

1) Or HA011066 (not intended for new designs)

### 5.1.1. EE160 Configuration using HA011070

#### NOTICE

The USB-C configuration stick HA011070 galvanically isolates the USB interface of the PC from the supply voltage of the EE160. When using the USB-C configuration stick the EE160 needs external supply.

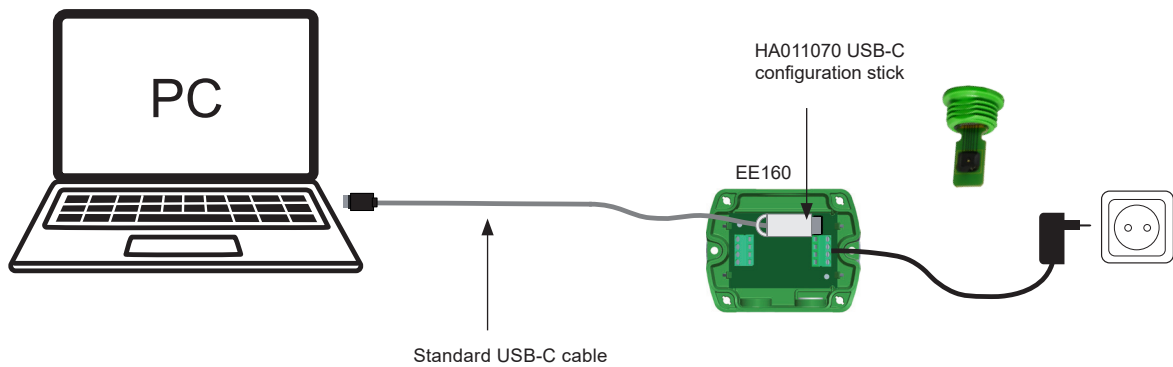

Fig. 3 EE160 configuration using the HA011070 USB-C configuration stick

### 5.1.2. EE160-M1TxJ3 (Digital Interface) Configuration Using HA011066 (not Intended for New Designs)

#### NOTICE

- For configuration of the EE160 with digital interface, using HA011066 either the supply of the configuration adapter HA011066 (for configuration purposes) or an external supply (for configuration, calibration and adjustment purposes) must be used.
- It is not permitted to use both (external supply and configuration adapter supply) at the same time.
- For best results the use of an external power supply is recommended for calibration and adjustment purposes.

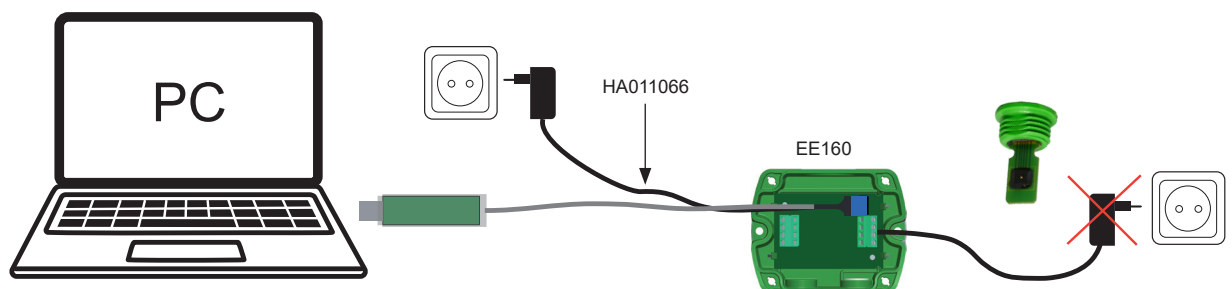

Fig. 4 EE160 configuration (digital interface) using the supply of HA011066

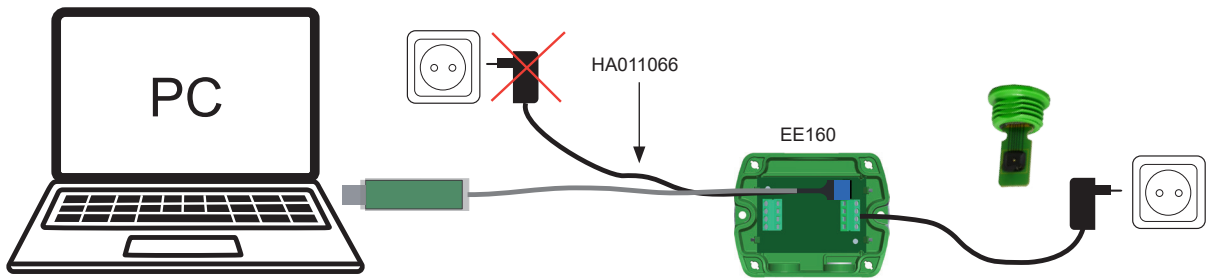

Fig. 5 EE160 configuration (digital interface) using the external supply

## 5.2 Product Configuration Adapter and Software for EE160 with New Sensing Element and Legacy Configuration Adapter HA011069 (not Intended for New Designs)

Remove the filter cap and check the sensing element of your EE160.



Fig. 6 EE160 with new sensing element

If the EE160 is equipped with a new sensing element according to the picture above it must only be configured or adjusted using the PCS10 Product Configuration Software (free download from [www.epluse.com/pcs10](http://www.epluse.com/pcs10)).

EE160 analogue versions can be configured using the legacy configuration adapter HA011069 (not intended for new designs) see table below.



Version	EE160 new sensing element	
	Configuration adapter	Configuration software
EE160-MxTxA3 Analogue voltage 0...10 V	HA011069	PCS10
EE160-MxTxA6 Analogue voltage 4...20 mA	HA011069	PCS10

Fig. 7 EE160 new sensing element

The USB configuration adapter HA011069 comes with a USB isolator that galvanically isolates the USB interface of the PC from the supply voltage of the EE160.

### **i** PLEASE NOTE

The USB configuration adapter HA011069 must always be operated together with the USB isolator.

### 5.2.1. EE160-MxTxA3 (Analogue Output, Voltage Version) with HA011069

#### NOTICE

- For the EE160 with voltage output, either the supply of the configuration adapter (for configuration purposes) or an external supply (for configuration, calibration and adjustment purposes) must be used.
- It is not permitted to use both (external supply and configuration adapter supply) at the same time.
- For best results the use of an external power supply is recommended for calibration and adjustment purposes.

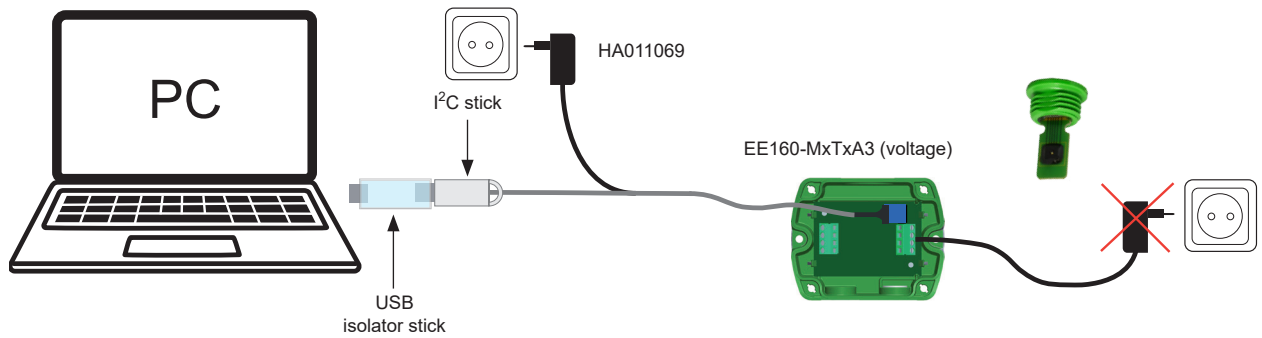

Fig. 8 EE160 configuration voltage output using HA011069 supply

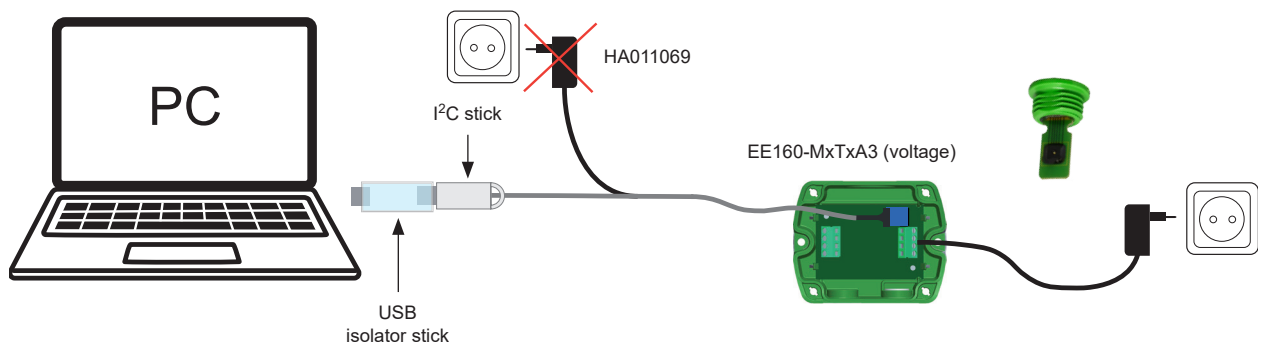

Fig. 9 EE160 configuration voltage output using external supply

### 5.2.2. EE160-MxTxA6 (Analogue Output, Current Version) with HA011069 (not Intended for New Designs)

#### NOTICE

- For the EE160 with current output an external supply must be used for configuration, calibration and adjustment purposes.
- It is not permitted to use the configuration adapter supply (only for voltage output).
- It is not permitted to use both (external supply and configuration adapter supply) at the same time.

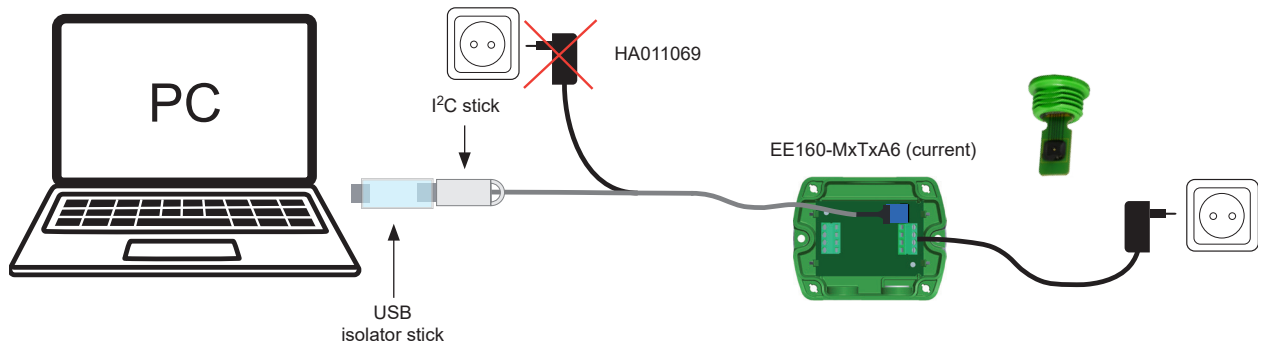

Fig. 10 EE160 configuration current output using external supply only

### 5.3 Product Configuration Adapter and Software for EE160 with Legacy Sensing Element

Remove the filter cap and check the sensing element of your EE160.



Fig. 11 EE160 with legacy sensing element

If the EE160 is equipped with a legacy sensing element according to the picture above, it must only be configured or adjusted using the EE-PCS Product Configuration Software (free download from [www.epluse.com/configurator](http://www.epluse.com/configurator)) and the adapters according to the following table:

Version	EE160 legacy sensing element	
	Configuration adapter	Configuration software
EE160-MxTxA3 Analogue voltage 0...10 V	EE-PCA + HA011059	EE-PCS
EE160-MxTxA6 Analogue voltage 4...20 mA	EE-PCA + HA011059	EE-PCS
EE160-M1TxJ3 Digital RS485 Modbus	HA011066	EE-PCS

Fig. 12 EE160 legacy sensing element

### 5.3.1. EE160-MxTxAx (Analogue Output)

#### NOTICE

EE160 with analogue output must be powered externally when using the EE-PCA kit.



Fig. 13 EE160 configuration analogue output using EE-PCA kit

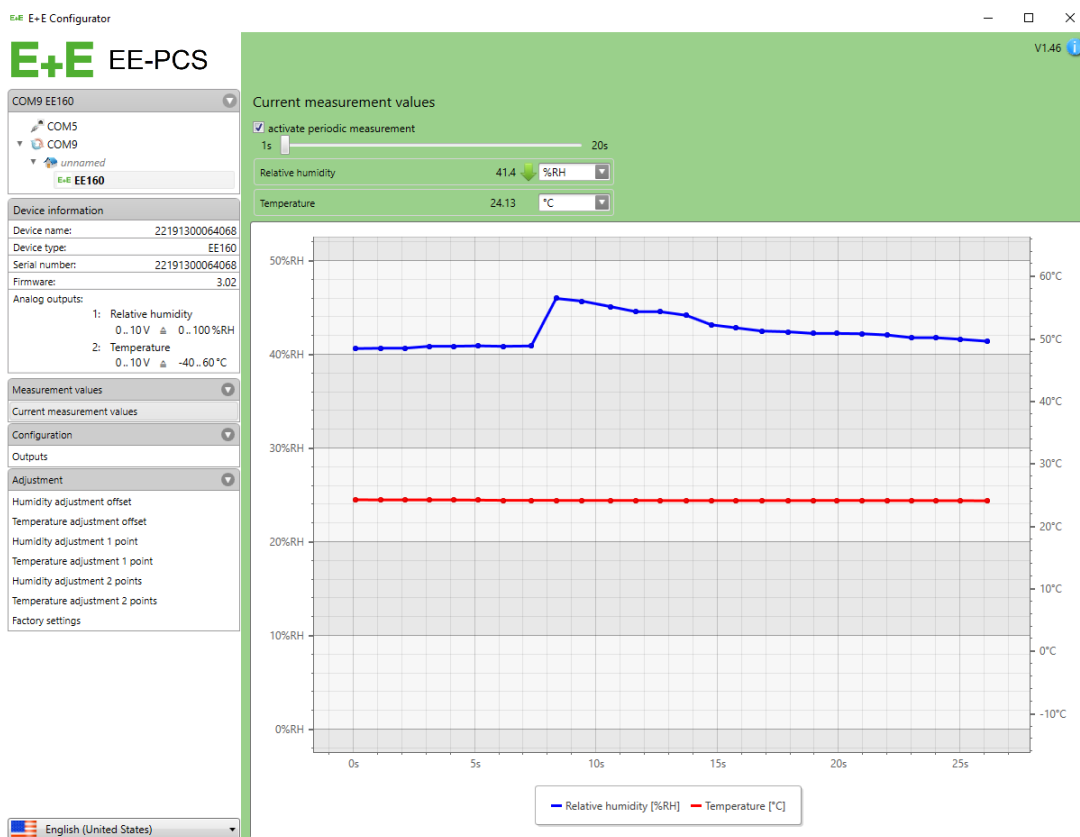

Fig. 14 EE-PCS software for analogue versions

### 5.3.2. EE160-M1TxJ3 (Digital Interface)

#### NOTICE

- For the EE160 with digital interface, either the supply of the configuration adapter HA011066 (for configuration purposes) or an external supply (for configuration, calibration and adjustment purposes) must be used.
- It is not permitted to use both (external supply and configuration adapter supply) at the same time.
- For best results the use of an external power supply is recommended for calibration and adjustment purposes.

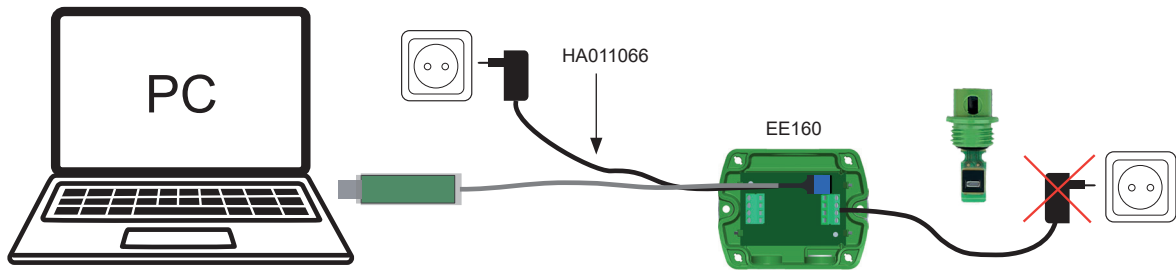

Fig. 15 EE160 configuration (digital interface) using the supply of HA011066

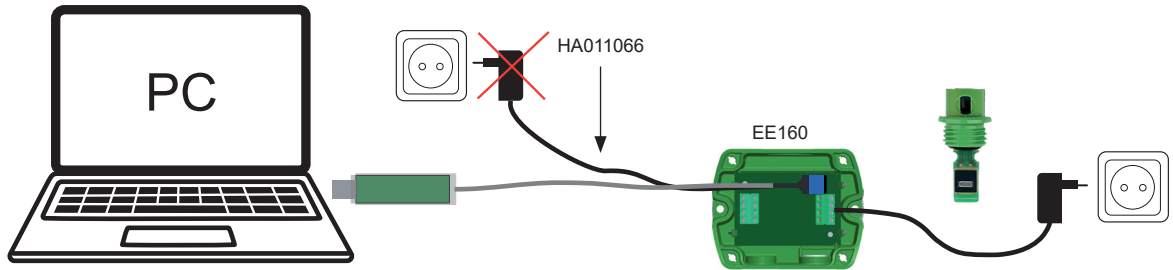

Fig. 16 EE160 configuration (digital interface) using external supply

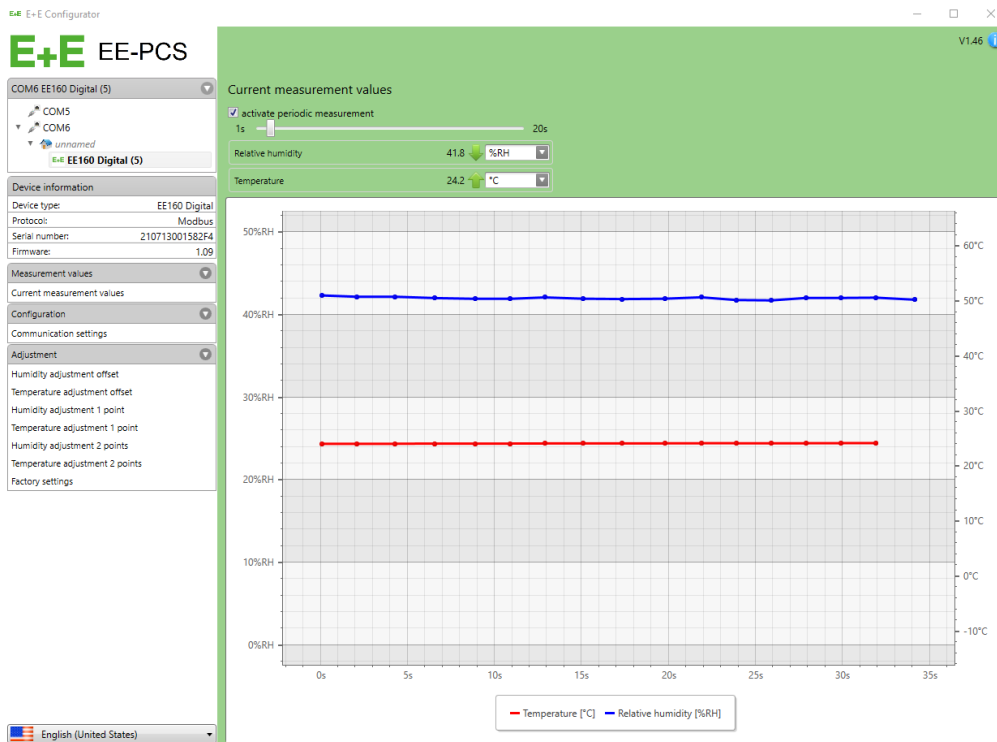

Fig. 17 EE-PCS software for digital interface

## 5.4 PCS10 Product Configuration Software

Use the software to perform adjustments and changes in settings, please proceed as follows:

1. Download the PCS10 Product Configuration Software from [www.epluse.com/pcs10](http://www.epluse.com/pcs10) and install it on the PC.
2. Connect the EE160 to the PC using the appropriate configuration adapter.
3. Start the PCS10 software.
4. Follow the instructions on the PCS10 opening page to scan the ports and to identify the connected device.
5. Click on the desired setup or adjustment mode from the main PCS10 menu on the left. Follow the PCS10 online instructions that are displayed when clicking on the “Tutorial” button.
6. Upload changes to the sensor by pressing the “Sync” button.

## 5.5 RS485 Digital Interface

### 5.5.1. Hardware Bus Termination

For bus termination EE160 features an internal 120 Ω resistor which can be activated using the jumper on the electronics board (refer to also chapter 3.3 Electrical Connection for details).

- Jumper not mounted (right position = factory setup): bus is not terminated

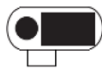

- Jumper mounted (left position): bus is terminated



### 5.5.2. Device Address

Address Switch	Option
<p>0 0 0 0 0 0 0 0</p>	<p><b>Address setting via PCS10 Product Configuration Software (= factory setting)</b></p> <p>All DIP switches at position 0 → factory-set default address (245<sub>DEC</sub>, 0xF5) applicable, can be changed via software (PCS10 or Modbus protocol, permitted values: 1...247).</p> <p>Example: Address is set via configuration software.</p>
<p>1 1 0 1 0 0 0 0</p>	<p><b>Address setting via DIP switches</b></p> <p>DIP switches in any other position than 0 indicate the effective Modbus address which overrules the factory setting and any Modbus address set via PCS10 or Modbus command (permitted values: 1...247).</p> <p>Example: Address set to 11<sub>DEC</sub> (0000 1011<sub>BIN</sub>).</p>

### 5.5.3. RS485 Digital Interface with Modbus RTU Protocol

	Factory settings	User selectable values (via PCS10)
Baud rate	9600	9 600, 19 200, 38 400, 57 600, 76 800, 115 200
Data bits	8	8
Parity	Even	None, odd, even
Stop bits	1	1, 2
Modbus address	245	1...247

Tab. 3 Digital interface default settings

#### **i PLEASE NOTE**

- The recommended settings for multiple devices in a Modbus RTU network are 9600, 8, even, 1. The EE160 represents 1 unit load on an RS485 network.

Device address, baud rate, parity and stop bits can be set via:

- PCS10 Product Configuration Software, the USB-C configuration stick HA011070.  
The PCS10 can be downloaded free of charge from [www.epluse.com/pcs10](http://www.epluse.com/pcs10)
- Modbus protocol in the register 1 (0x00) and 2 (0x01).  
See Modbus Application Note AN0103 (available at [www.epluse.com/ee160](http://www.epluse.com/ee160))

The serial number as ASCII-code is located in read-only registers 1 - 8 (0x00 - 0x07, 16 bits per register).  
The firmware version is located in register 9 (0x08) (bit 15...8 = major release; bit 7...0 = minor release).  
The sensor name as ASCII-code is located in read-only registers 10 - 17 (0x09 - 0x10).

The beforementioned registers can be read out with function code 0x03 or 0x04.

## NOTICE

When reading information that spans multiple registers, it is always necessary to read all registers, even if the desired information requires less.

## NOTICE

To obtain the correct floating point values, both registers have to be read within the same reading cycle. The measured value may change between two Modbus requests. This can cause inconsistencies in the exponent and mantissa.

## INFO

The Modbus function codes mentioned throughout this document shall be used as described in chapter 6 of of [MODBUS APPLICATION PROTOCOL SPECIFICATION V1.1b3](https://www.modbus.org/), available at <https://www.modbus.org/>.

### Communication settings (INT16)

Parameter	Register number <sup>1)</sup> [Dec]	Register address <sup>2)</sup> [Hex]	Size <sup>3)</sup>
Write register: function code 0x06			
Modbus address <sup>4)</sup>	1	00	1
Modbus protocol settings <sup>4)</sup>	2	01	1

### Device information (INT16)

Parameter	Register number <sup>1)</sup> [Dec]	Register address <sup>2)</sup> [Hex]	Size <sup>3)</sup>
Read register: function code 0x03 / 0x04			
Serial number (as ASCII)	1	00	8
Firmware version	9	08	1
Sensor name (as ASCII)	10	09	8

1) Register number (decimal) starts from 1.

2) Register address (hexadecimal) starts from 0.

3) Number of registers

4) For Modbus address and protocol settings see Application Note Modbus AN0103 (available at [www.epluse.com/ee160](http://www.epluse.com/ee160)).

Tab. 4 EE160 registers for device setup



**Decoding of floating point values:**

Floating point values are interpreted according to IEEE754. The byte pairs [1], [2] and [3], [4] are transformed as follows (register contents taken from the T reading Modbus request/response example above):

Modbus response [Hex]							
Register 1 Hi	[3]	Register 1 Lo	[4]	Register 2 Hi	[1]	Register 2 Lo	[2]
51		F0		41		BA	
MMMM	MMMM	MMMM	MMMM	SEEE	EEEE	EMMM	MMMM

Tab. 7 Modbus response

IEEE754							
Register 2 Hi	[1]	Register 2 Lo	[2]	Register 1 Hi	[3]	Register 1 Lo	[4]
41		BA		51		F0	
0100	0001	1011	1010	0101	0001	1111	0000
SEEE	EEEE	EMMM	MMMM	MMMM	MMMM	MMMM	MMMM
Decimal value: 23.290008							

Tab. 8 Data representation according to IEEE754

## 6 Maintenance and Service

### 6.1 Calibration and Adjustment

#### Definitions

- **Calibration** documents the accuracy of a measurement device. The device under test (specimen) is compared with the reference and the deviations are documented in a calibration certificate. During the calibration, the specimen is not changed or improved in any way.
- **Adjustment** improves the measurement accuracy of a device. The specimen is compared with the reference and brought in line with it. An adjustment can be followed by a calibration which documents the accuracy of the adjusted specimen.

### 6.2 RH and T Adjustment and Calibration

#### Humidity calibration and adjustment

Depending on the application and the requirements of certain industries, there might arise the need for periodical humidity calibration (comparison with a reference) or adjustment (bringing the device in line with a reference).

#### Calibration and adjustment at E+E Elektronik

Calibration and/or adjustment can be performed in the E+E Elektronik calibration laboratory. For information on the E+E capabilities in ISO or accredited calibration please see [www.eplusecal.com](http://www.eplusecal.com) and [www.epluse.com/iso9001cal](http://www.epluse.com/iso9001cal).

#### Calibration and adjustment by the user

Depending on the level of accuracy required, the humidity reference can be:

- Humidity Calibrator (e.g. Humor 20), please see [www.epluse.com](http://www.epluse.com).
- Handheld Device (e.g. Omniport40), please see [www.epluse.com/omniport40](http://www.epluse.com/omniport40).
- Humidity Calibration Kit (e.g. E+E Humidity Standards), please see [www.epluse.com/ee160](http://www.epluse.com/ee160).

## 6.3 Cleaning the Sensing Head and Filter Cap Replacement

### Cleaning the sensing head:

Use in polluted environment might rise the need for cleaning the sensing head and replacing the filter cap. In such a case refer to “Cleaning Instructions” at [www.epluse.com/ee160](http://www.epluse.com/ee160).

### When employed in dusty, polluted environment:

- The filter cap shall be replaced once in a while with an E+E original one. A polluted filter cap causes longer response time of the device.
- If needed, the sensing head can be cleaned. For cleaning instructions please see [www.epluse.com/ee160](http://www.epluse.com/ee160).

### **i** PLEASE NOTE

While replacing the filter cap take very good care to not touch or rub the sensing element.

## 6.4 Display Exchange

### NOTICE

Disconnecting or connecting the display while the EE160 is powered may cause damages to EE160 and to the display. Always switch off the EE160 before exchanging the display.

The accessory D10P comes with the display included in the top part of the EE160 enclosure. It is intended for replacement only, not for retrofitting an EE160 originally ordered without display.

Procedure for Display exchange:

1. Strictly observe ESD precautions. The sensing elements and the electronics board are ESD (electrostatic discharge) sensitive components of the device and must be handled as such. The failure to do so may damage the device by electrostatic discharges when touching exposed sensitive components.
2. Switch off the power supply of the EE160.
3. Open the FFC Connector and plug off the FFC cable from the display PCB included in the top part of the EE160 enclosure.
4. Connect the FFC cable to the new display. Please observe the correct orientation. The blue cable stiffener needs to be visible as shown in Fig. 18.
5. Switch on power supply to bring the EE160 back into operation.

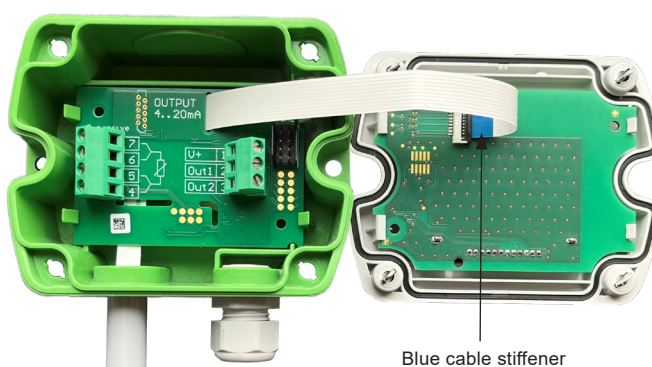

Fig. 18 Correct connection of the display FFC cable

## 6.5 Repairs

### **i** PLEASE NOTE

Repairs may only be carried out by the manufacturer. The attempt of unauthorised repair excludes any warranty claims.

# 7 Accessories

For further information see datasheet [Accessories](#).

Accessories	Code
E+E Product configuration software (Free download: <a href="http://www.epluse.com/pcs10">www.epluse.com/pcs10</a> )	PCS10
Power supply adapter 24 V DC	V03
Protection cap for Ø12 mm (0.47") probe, RAL6018	HA010783
USB-C configuration stick	HA011070
<b>EE160 configuration with legacy sensing element (see chapter 5.3)</b>	
E+E Product configuration software (Free download: <a href="http://www.epluse.com/configurator">www.epluse.com/configurator</a> )	EE-PCS
E+E Product Configuration Adapter + EE160 Cable Analogue	EE-PCA + HA011059

# 8 Technical Data

## Measurands

### Relative Humidity (RH)

Measuring range	0...100 %RH, non-condensing									
Accuracy <sup>1)</sup> (incl. hysteresis, non-linearity and repeatability)	<table border="0"> <tr> <td>23 °C (0...100 %RH)</td> <td>±2 %RH</td> </tr> <tr> <td>0...+40 °C (0...100 %RH)</td> <td>±2.5 %RH</td> </tr> <tr> <td>-20...+60 °C (0...100 %RH)</td> <td>±3.5 %RH</td> </tr> <tr> <td>-40...-20 °C (0...100 %RH)</td> <td>±4.5 %RH</td> </tr> </table>		23 °C (0...100 %RH)	±2 %RH	0...+40 °C (0...100 %RH)	±2.5 %RH	-20...+60 °C (0...100 %RH)	±3.5 %RH	-40...-20 °C (0...100 %RH)	±4.5 %RH
23 °C (0...100 %RH)	±2 %RH									
0...+40 °C (0...100 %RH)	±2.5 %RH									
-20...+60 °C (0...100 %RH)	±3.5 %RH									
-40...-20 °C (0...100 %RH)	±4.5 %RH									
Factory calibration uncertainty <sup>2)</sup>	<table border="0"> <tr> <td>0...90 %RH</td> <td>±(0.7 + 0.003 * mv) %RH</td> </tr> <tr> <td>&gt;90...100 %RH</td> <td>±1 %RH</td> </tr> </table>	0...90 %RH	±(0.7 + 0.003 * mv) %RH	>90...100 %RH	±1 %RH	mv = measured value				
0...90 %RH	±(0.7 + 0.003 * mv) %RH									
>90...100 %RH	±1 %RH									

1) Defined against E+E calibration reference.

2) Defined at 23 °C (73.4 °F) with a coverage factor k=2, corresponding to a confidence level of 95 %.

### Temperature (T)

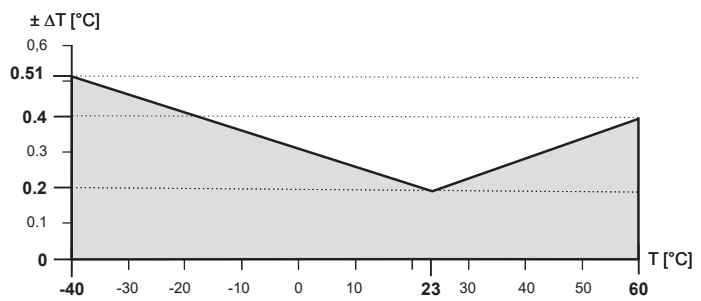
Measuring range	-40...+60 °C (-40...+140 °F)									
Accuracy <sup>1)</sup>	 <table border="1"> <caption>Temperature Accuracy Data</caption> <thead> <tr> <th>T [°C]</th> <th>±ΔT [°C]</th> </tr> </thead> <tbody> <tr> <td>-40</td> <td>0.51</td> </tr> <tr> <td>23</td> <td>0.2</td> </tr> <tr> <td>60</td> <td>0.4</td> </tr> </tbody> </table>		T [°C]	±ΔT [°C]	-40	0.51	23	0.2	60	0.4
T [°C]	±ΔT [°C]									
-40	0.51									
23	0.2									
60	0.4									
Factory calibration uncertainty <sup>2)</sup>	±0.1 °C (±0.18 °F)									

1) Defined against E+E calibration reference.

2) Defined at 23 °C (73.4 °F) with a coverage factor k=2, corresponding to a confidence level of 95 %.

## Outputs

### Analogue

<b>RH: 0...100 %</b> , <b>T: see ordering guide</b>	4 – 20 mA (2-wire) 0 – 10 V	$R_L \leq 500 \Omega$ $0 \text{ mA} < I_L < 1 \text{ mA}$	$R_L = \text{load resistance}$ $I_L = \text{load current}$
<b>Accuracy</b> @23 °C (68 °F)	± 0.075 % fs		fs = full scale (20 mA, 10 V)



### T Sensor Passive

<b>Type acc. to ordering code</b>	4-wire connection
-----------------------------------	-------------------

### Digital

<b>Digital interface</b>	RS485 (EE160 = 1 unit load)
<b>Protocol</b> <b>Factory settings</b> <b>Supported baud rates</b> <b>Data types for measured values</b>	Modbus RTU Baud rate acc. to ordering code, parity even, 1 stop bit, Modbus address 245 9 600, 19 200, 38 400, 57 600, 76 800 and 115 200 FLOAT32 and INT16

## General

<b>Power supply</b> class III  USA & Canada: Class 2 supply necessary, max. voltage 30 V DC	<b>4 – 20 mA (2-wire)</b>	$(10 \text{ V} + R_L * 20 \text{ mA}) < V+ < 35 \text{ V DC}$		
	<b>0 – 10 V</b> <b>RS485</b>	15 – 35 V DC or 24 V AC ±20%		
<b>Current consumption</b> , typ.		<b>4 – 20 mA output</b>	<b>0 – 10 V output</b>	<b>RS485</b>
	<b>24 V DC supply</b>	According to output current, max. 40 mA	<3 mA / <5 mA with Display	5 mA
	<b>24 V AC supply</b>	-	<8 mA <sub>rms</sub> / <10 mA <sub>rms</sub> with Display	15 mA <sub>rms</sub>
<b>Electrical connection</b>	Screw terminals max. 1.5 mm <sup>2</sup> (AWG 16)			
<b>Cable gland</b>	M16x1.5			
<b>Display<sup>1)</sup></b>	LC display with two lines for RH and T values			
<b>Temperature range</b>		<b>Without display</b>	<b>With display</b>	
	<b>Operation</b>	-40...+60 °C (-40...+140 °F)	-20...+60 °C (-4...+140 °F)	
	<b>Storage</b>	-40...+60 °C (-40...+140 °F)	-20...+60 °C (-4...+140 °F)	
<b>Enclosure</b>	<b>Material</b>	Polycarbonate (PC), UL94 V-0 approved		
	<b>Protection rating</b>	IP65 / NEMA 4X		
<b>Electromagnetic compatibility</b>	EN 61326-1 FCC Part15 Class A	EN 61326-2-3 ICES-003 Class A	Industrial environment	
<b>Conformity</b>	EN 45545-2 (HL3)			

1) For display operation with EE160-MxA6 (4 – 20 mA, 2-wire) both outputs must be connected.

## Accuracy of E+E Humidity and Temperature Sensors

The measurement accuracy depends both on the performance of the measuring instrument and on the correct installation in the application.

For best accuracy, every E+E RH and T sensor is multipoint factory adjusted and calibrated in a highly stable RH / T reactor. Using a high-precision dew point mirror as reference, the overall uncertainty of the factory calibration  $U_{\text{cal}}$  is minimal.

The total measurement uncertainty  $U_{\text{total}}$  for E+E sensors is calculated in accordance with EA-4/02 (European Accreditation, Evaluation of the Measurement Uncertainty in Calibration) and with GUM (Guide to the Expression of Uncertainty in Measurement) as follows:

$$U_{\text{total}} = k \cdot \sqrt{\left(\frac{U_{\text{cal}}}{2}\right)^2 + \left(\frac{U_{\text{accuracy}}}{\sqrt{3}}\right)^2}$$

$U_{\text{total}}$  .....total accuracy incl. factory calibration

$U_{\text{cal}}$  .....the uncertainty of the factory calibration

$U_{\text{accuracy}}$  .....the accuracy of the measurement device

$k$  .....coverage factor  $k=2$ , corresponding to a confidence level of 95 %.

For external calibrations,  $U_{\text{total}}$  is to be used as the evaluation criterion. The calculation does not include effects due to long-term drift or chemical exposure.

As National Metrological Institute (NMI) / Designated Institute (DI) responsible for maintaining National Standards in Austria, E+E Elektronik represents the highest level in calibration. For further details, please refer to [www.eplusecal.com](http://www.eplusecal.com).

## 9 Conformity

### 9.1 Declarations of Conformity

E+E Elektronik Ges.m.b.H. hereby declares that the product complies with the respective regulations listed below:



European directives and standards.

and



UK statutory instruments and designated standards.

Please refer to the product page at [www.epluse.com/ee160](http://www.epluse.com/ee160) for the Declarations of Conformity.

### 9.2 Electromagnetic Compatibility

EMC for industrial environment.

The sensor is a group 1 device and corresponds to Class A.

#### WARNING

This device is not intended for use in residential areas and cannot ensure adequate protection of radio reception in such environments.

### 9.3 FCC Part 15 Compliance Statement

This equipment has been tested and found to comply with the limits for a Class A digital device, pursuant to part 15 of the FCC Rules. These limits are designed to provide reasonable protection against harmful interference when the equipment is operated in a commercial environment. This equipment generates, uses, and can radiate radio frequency energy and, if not installed and used in accordance with the instruction manual, may cause harmful interference to radio communications. Operation of this equipment in a residential area is likely to cause harmful interference in which case the user will be required to correct the interference at his own expense.

### 9.4 ICES-003 Compliance Statement

This Class A digital apparatus complies with Canadian ICES-003.

Cet appareil numérique de la classe A est conforme à la norme NMB-003 du Canada.

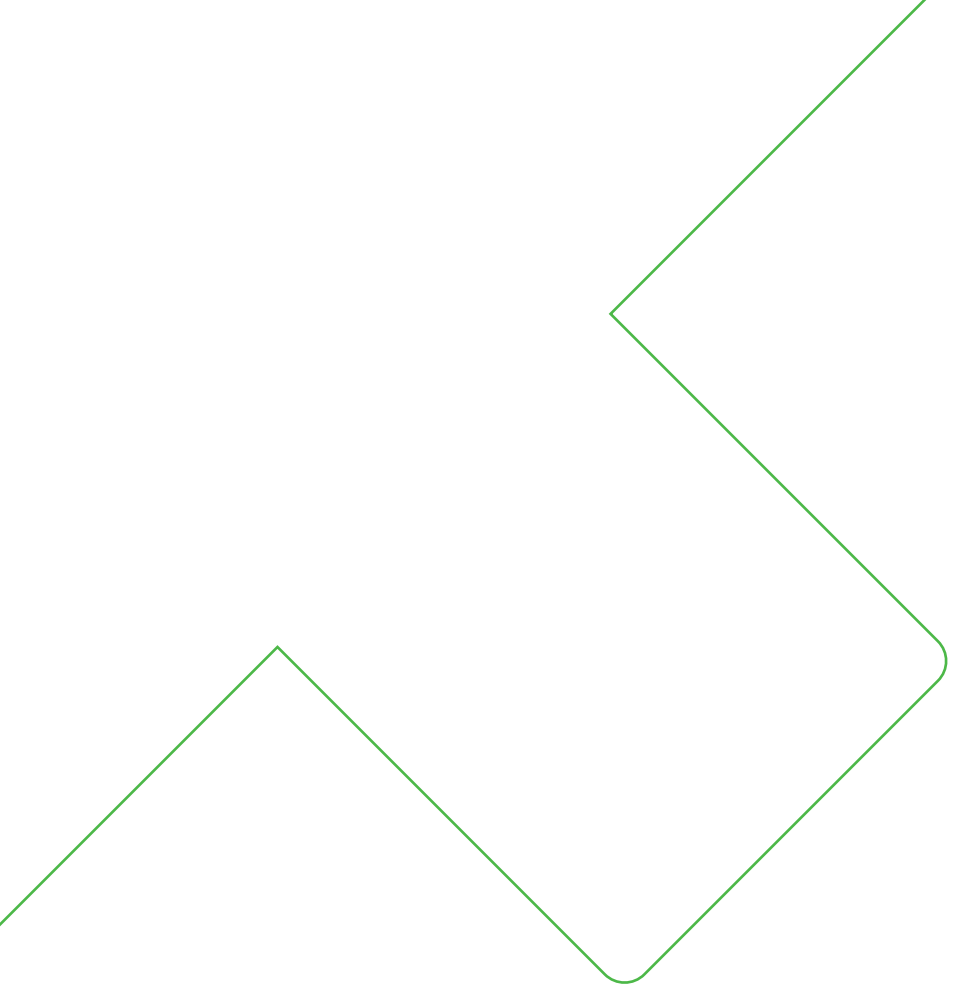

Company Headquarters &  
Production Site

**E+E Elektronik Ges.m.b.H.**  
Langwiesen 7  
4209 Engerwitzdorf | Austria  
T +43 7235 605-0  
F +43 7235 605-8  
info@epluse.com  
www.epluse.com

Subsidiaries

**E+E Sensor Technology (Shanghai) Co., Ltd.**  
T +86 21 6117 6129  
info@epluse.cn

**E+E Elektronik France SARL**  
T +33 4 74 72 35 82  
info.fr@epluse.com

**E+E Elektronik Deutschland GmbH**  
T +49 6171 69411-0  
info.de@epluse.com

**E+E Elektronik India Private Limited**  
T +91 990 440 5400  
info.in@epluse.com

**E+E Elektronik Italia S.r.l.**  
T +39 02 2707 86 36  
info.it@epluse.com

**E+E Elektronik Korea Ltd.**  
T +82 31 732 6050  
info.kr@epluse.com

**E+E Elektronik Corporation**  
T +1 847 490 0520  
info.us@epluse.com



—  
your partner  
in sensor  
technology.