

## Instruction for use

021505/04/11

---

# ***Brightness Transmitter***

**7.1414.6x.0xx**



### **ADOLF THIES GmbH & Co. KG**

Hauptstraße 76                      37083 Göttingen Germany  
Box 3536 + 3541                      37025 Göttingen  
Phone +49 551 79001-0              Fax +49 551 79001-65  
www.thiesclima.com                  info@thiesclima.com

## **Contents**

1	Models .....	3
2	Application .....	3
3	Mode of Operation .....	3
4	Installation.....	6
4.1	Mechanical Mounting .....	6
4.1.1	Examples for Mounting Alternatives .....	7
4.2	Electrical Mounting .....	8
4.3	Setting of the Heating Device.....	8
5	Maintenance .....	8
6	Connecting Diagrams .....	9
7	Technical Data .....	10
8	Dimensional Drawing .....	11
9	Diagram – Heating .....	11
10	EC-Declaration of Conformity.....	12

## **Figures**

Figure 1:	Horizontal (Azimuth) direction-dependency of the brightness with model 7.1414.60.0xx.	5
Figure 2:	Horizontal (Azimuth) direction-dependency of the brightness with model 7.1414.61.0xx.	5
Figure 3:	North marking.....	6

# 1 Models

---

Order-No.	Meas. Range	Elect. -Output	Numbers of Sectors and Outputs
7.1414.60.000	0...100 000 Lux	0...10 V	8
7.1414.60.040	0...100 000 Lux	0...20 mA	8
7.1414.60.041	0...100 000 Lux	4...20 mA	8
7.1414.61.000	0...100 000 Lux	0...10 V	3
7.1414.61.040	0...100 000 Lux	0...20 mA	3
7.1414.61.041	0...100 000 Lux	4...20 mA	3

## 2 Application

---

The brightness transmitter serves for the **acquisition of sun position-dependent intensities** of the daylight. The physical measuring values are output as light-proportional voltages or currents, and are used, for ex. for sun position-dependent control of shading devices, heating- and irrigation plants.

- The measuring value “brightness” of the model 7.1414.60.0xx is acquired by eight independent sensors (photo diodes) which are arranged in 45°-segments (North, NE, East, SE, South, SW, West, NW).
- The measuring value “brightness” of the model 7.1414.61.0xx is acquired by three independent sensors (photo diodes) which are arranged in 90°-segments (East, South, West).

## 3 Mode of Operation

---

*Brightness Transmitter 7.1414.60.0xx :*

By means of eight sensors (photo diodes), and the connected electronics the incident light is transformed into eight proportional output values, which are linear to the brightness. Each electrical output corresponds to a sector of 45° degrees. The sectors are centrally related to the directions.

1. Sector: North = 337,5° - 22,5°
2. Sector: NE = 22,5° - 67,5°
3. Sector: East = 67,5° - 112,5°
4. Sector: SE = 112,5° - 157,5°
5. Sector: South = 157,5° - 202,5°
6. Sector: SW = 202,5° - 247,5°
7. Sector: West = 247,5° - 292,5°
8. Sector: NW = 292,5° - 337,5°

*Brightness Transmitter 7.1414.61.0xx :*

By means of three sensors (photo diodes), and the connected electronics the incident light is transformed into eight proportional output values, which are linear to the brightness. Each electrical output corresponds to a sector of 90° degrees. The sectors are centrally related to the directions

1. Sector: East = 45° - 135°
2. Sector: South = 135° - 225°
3. Sector: West = 225° - 315°

---

**Remark:**

*The sensors (photodiodes) acquire the brightness related to a vertical surface.*

*In order to avoid a possible dewing the brightness transmitters are equipped with a heating device.*

---

---

**Note:** for *Brightness Transmitter with voltage output 7.1414.6x.000 :*

*A parallel connection of the outputs is possible. Thereby, free selectable acquisition ranges can be generated by more than one direction elements (for ex. monitoring ranges from N+NE+E). The highest value is delivered at the shared output.*

---

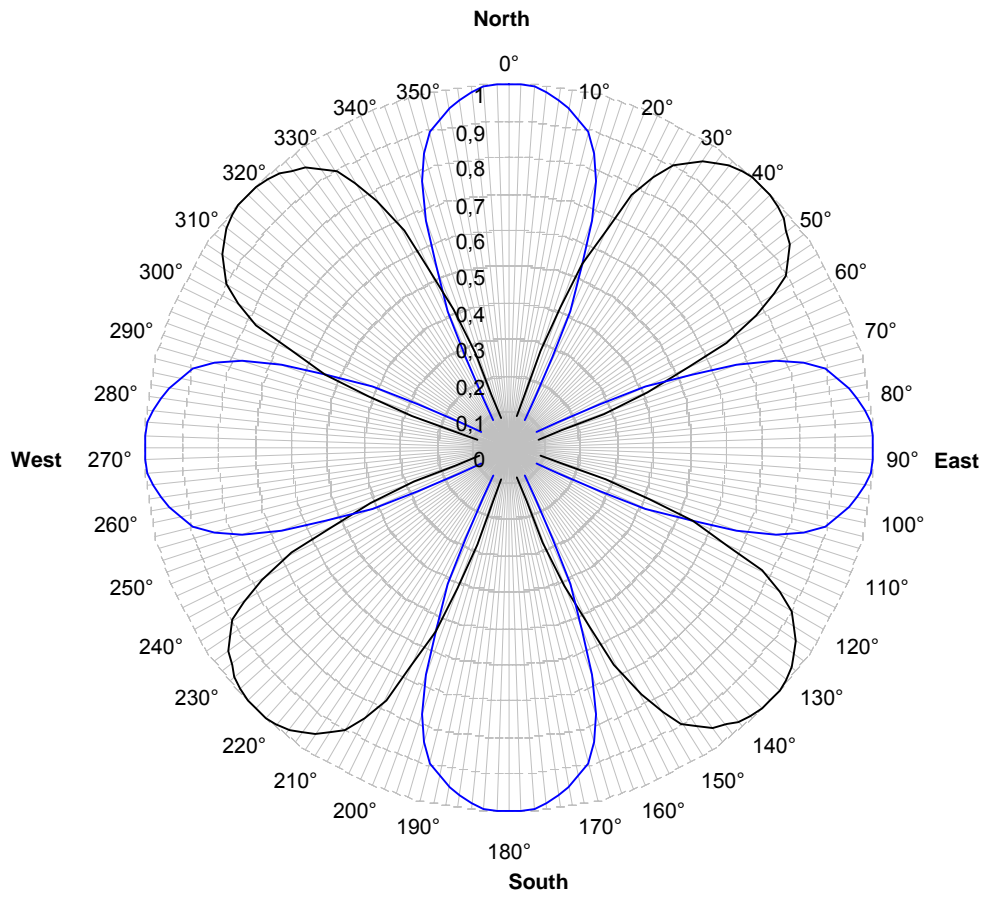

**Figure 1:** Horizontal (Azimuth) direction-dependency of the brightness with model 7.1414.60.0xx

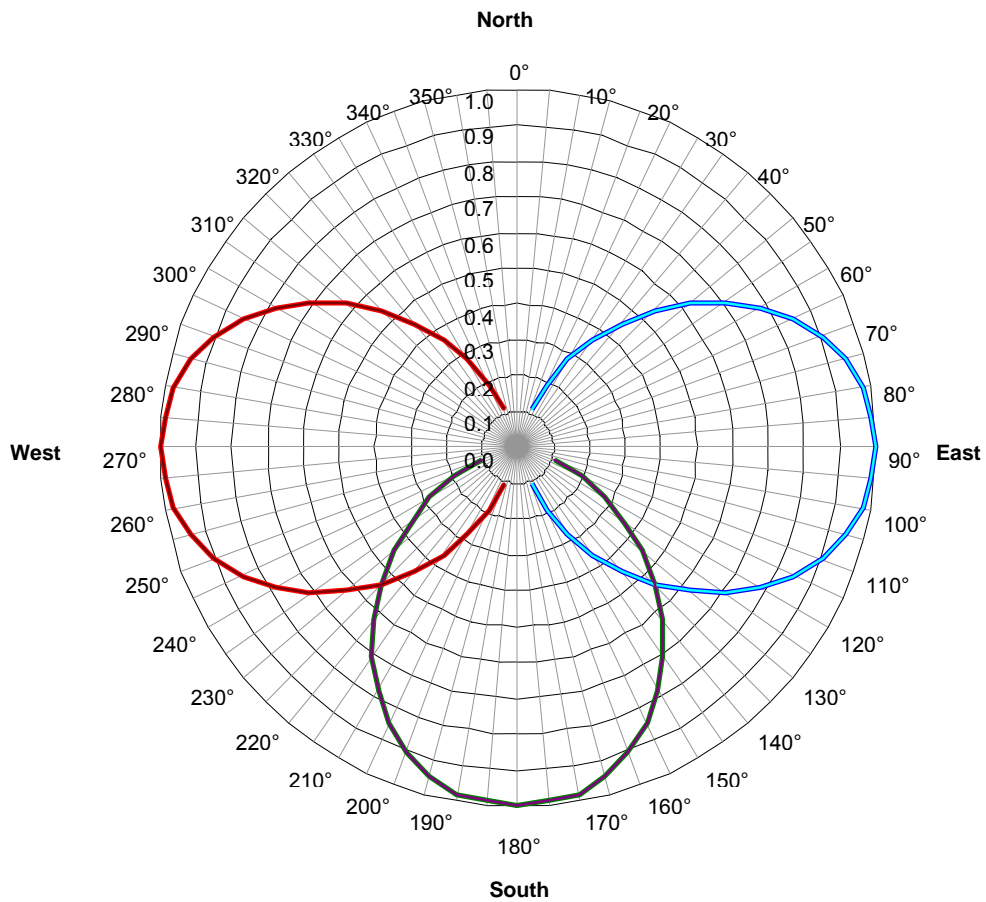

**Figure 2:** Horizontal (Azimuth) direction-dependency of the brightness with model 7.1414.61.0xx

## 4 Installation

---

### **Remark:**

*When mounting the instrument, please take into consideration that the sensor evaluates also reflected light, and accumulates it to the direct incident sun light. At locations with reflecting surfaces the measuring values are considerably higher than they would be in the free field, or in front of a hardly reflecting surface.*

*The instrument must not be installed in the shades of buildings, parts of buildings, masts, antennas, trees, bushes etc., as otherwise the proper ambient brightness or the direct sun radiation is not acquired correctly.*

---

### **Attention:**

***The electrical connection must be carried out only by a qualified expert.***

***The instrument must be opened only in dry conditions.***

***The uncovered electronics must not be damaged.***

### 4.1 Mechanical Mounting

The brightness transmitter is designed to be mounted to a horizontal surface out-of-doors. It is recommended to carefully choose a location which is free of shades and reflections.

For installation please unscrew and remove the housing cover. Through the now accessible mounting boreholes the instrument is fastened by the respective screws.

For the optimum acquisition of the sun position the brightness transmitter is aligned by means of a compass, so that the side of the housing with the north marking indicates to the (geographical) Northern direction.



**Figure 3: North marking**

#### 4.1.1 Examples for Mounting Alternatives

- Mounting of the brightness transmitter at a mast top through holder, and adaptor.

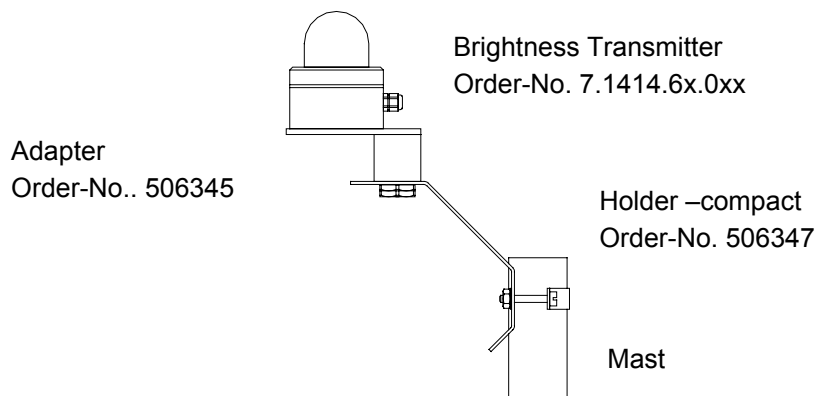

- Mounting of the brightness transmitter below a mast top through traverse and adaptor.  
In order to minimize reflections it is recommended to blacken the mast, above the traverse, acc. to the length of the traverse.

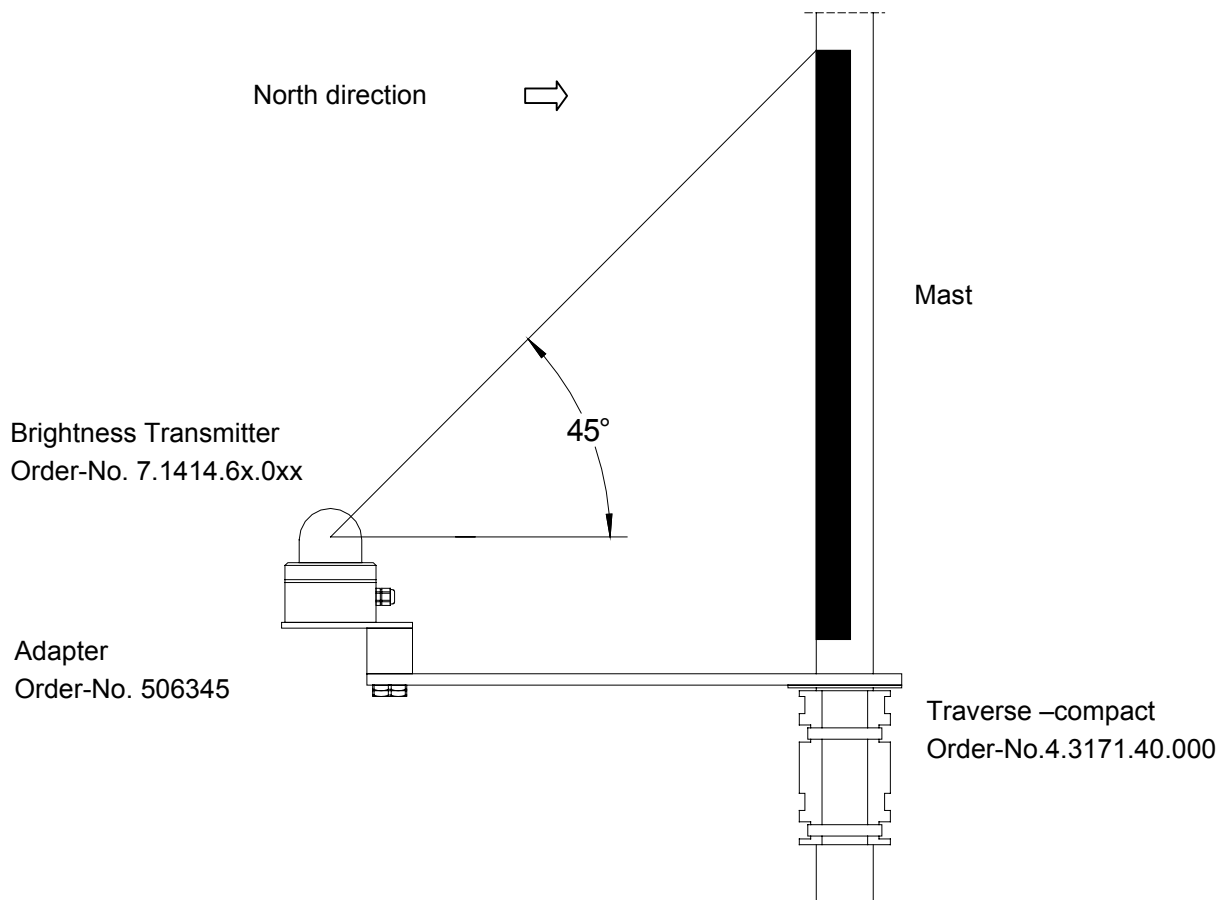

---

**Remark:**

*Mast, holder, traverse, and adaptor are not included in delivery*

---

## 4.2 Electrical Mounting

Use a shielded LiYCY 12 x 0,25 mm<sup>2</sup> (6 x 0,25 mm<sup>2</sup>) cable to connect the instrument electrically. Lead the cable through the screwed cable gland and place it on the terminal strip as shown in the connecting diagram. Ground the shielding.

After wiring of the instrument the nut of the cable gland, and screws of the housing cover are to be screwed tightly together with the base part of the housing.

## 4.3 Setting of the Heating Device

On status of delivery the heating is activated. In case a deactivation should be carried out please unscrew and remove the housing cover. Open the bridge P4 on the pc-board which is now visible.

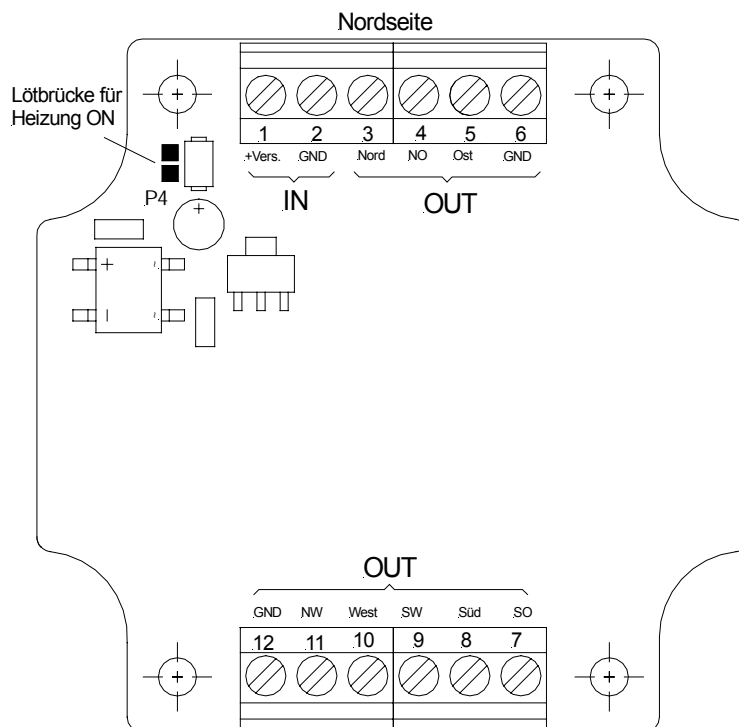

## 5 Maintenance

Clean the light dome at regular intervals – depending on the extent of soiling – with a soft cloth and pure water (no additives).



## 6 Connecting Diagrams

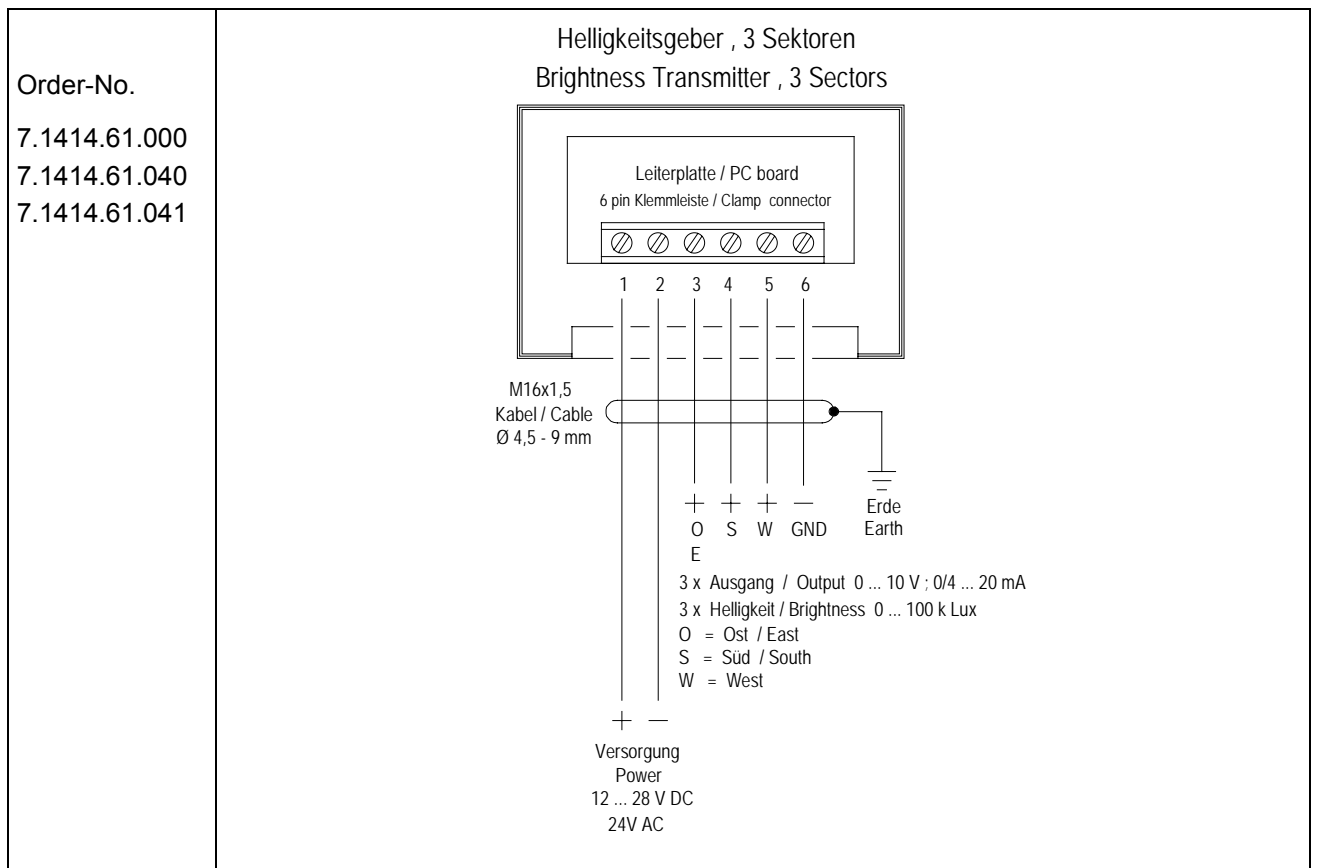
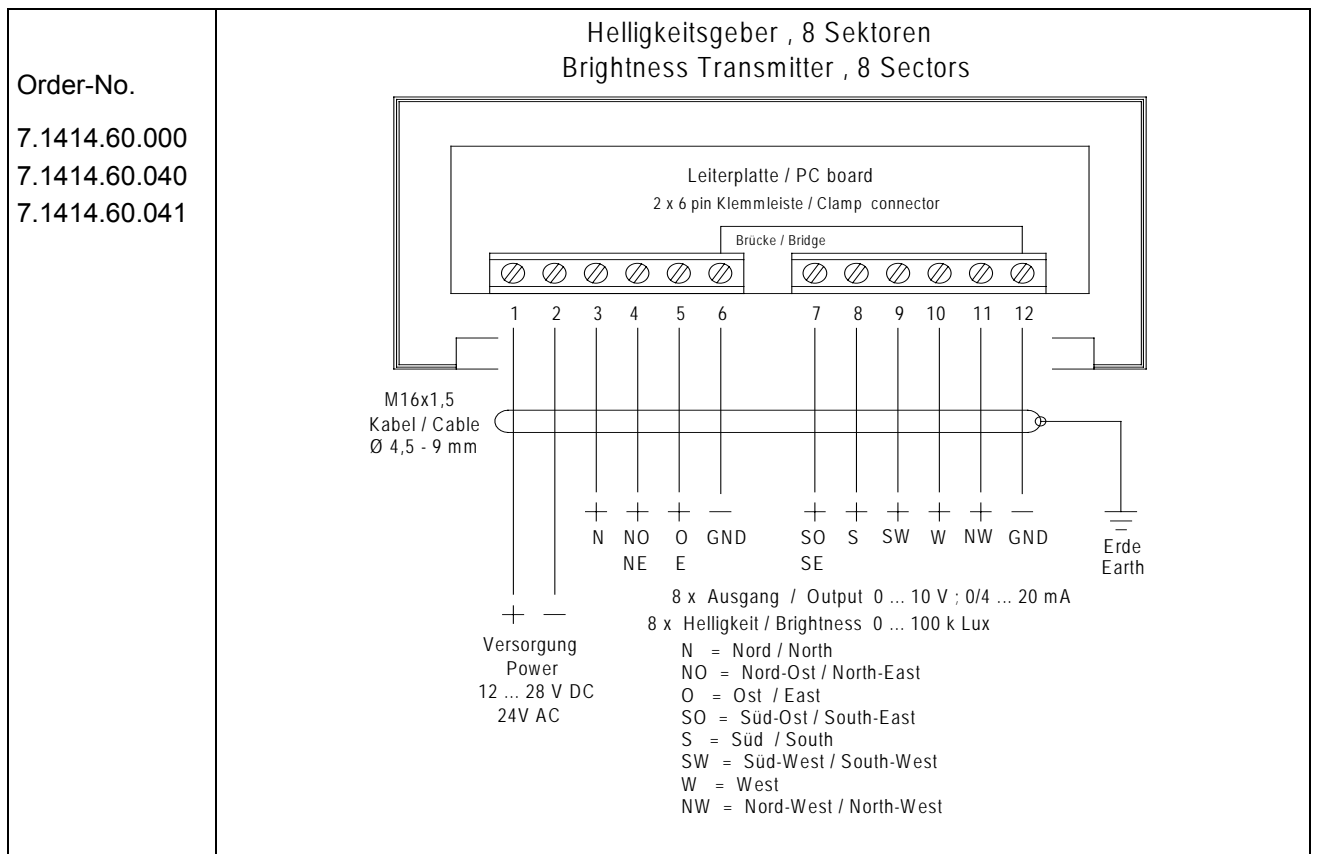

## 7 Technical Data

Measuring range		0 ... 100 kLux
Sensor		SFH 206 K
Spectral range		400... 1100 nm
Accuracy		± 2% of measuring range with vertical light incidence on the photodiode
Acquisition angel with 7.1414.60.000	Elevation	0... 90°
	Azimuth	8 x ± 22,5°
Acquisition angel with 7.1414.61.000	Elevation	0... 90°
	Azimuth	3 x ± 45°
Electrical output		The outputs are shortcut-safe. The outputs can be connected in parallel
	7.1414.6x.000	0...10 V per Sector; voltage- limited to ≤ 10,5 V
	7.1414.6x.040	0...20 mA per Sector; current limited to ≤ 20,5 mA
	7.1414.6x.041	4...20 mA per Sector; current limited to ≤ 20,5 mA
Operating voltage		12...28 VDC / 24VAC
Load resistance	7.1414.6x.000	≥ 1000 Ω
Load	7.1414.6x.04x	≤ 350 Ω
Operating current	7.1414.6x.000	ca. 10 mA w/o heating (w/o signal currents) max. 250 mA with heating
	7.1414.60.04x	< 170 mA w/o heating (= 10 mA + 8x Iout) < 400 mA with heating
	7.1414.61.04x	< 70 mA w/o heating (= 10 mA + 3x Iout) < 300 mA with heating
Ambient temperature		- 30...+ 70° C
Protection		IP 65
Weight		150g
Connection		Screwed cable gland and clamp connector

## 8 Dimensional Drawing

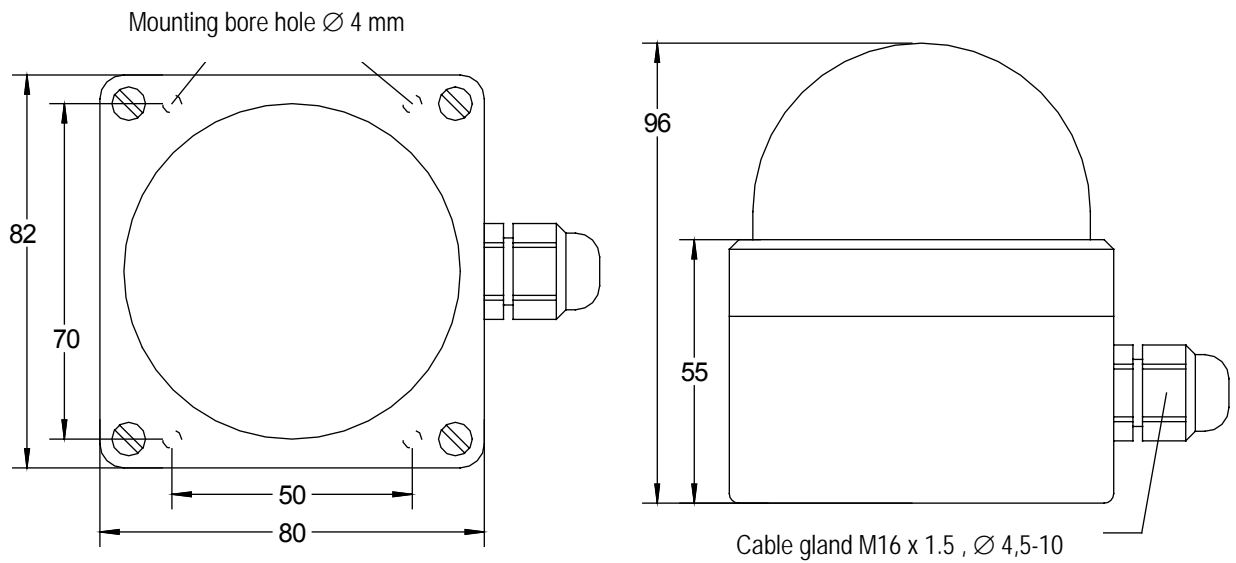

## 9 Diagram – Heating

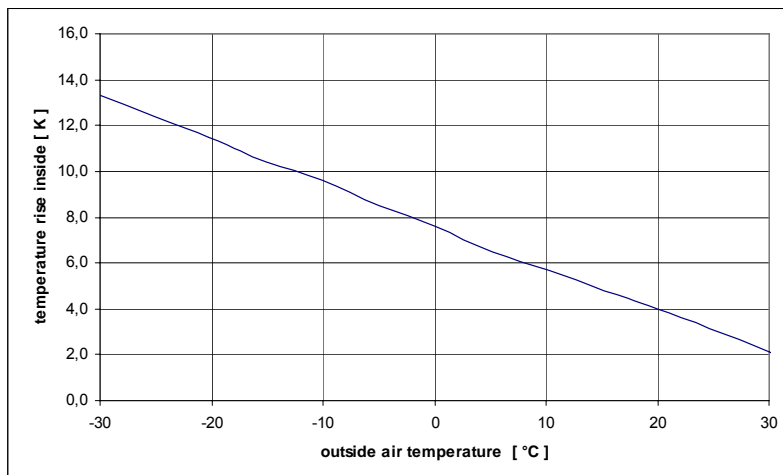

Inside - outside – difference temperature by using the heating.

- When the outside temperature is falling the heating capacity raises.
- At a power supply of 24 V the heating current is flowing as follows  
+30°C approx. 20 mA  
-30 °C approx. 140 mA
- The raised inside temperature prevents the light dome from being moistened by dew.

# 10 EC-Declaration of Conformity

Document-No.: 000318

Month: 04 Year: 11

Manufacturer: **ADOLF THIES GmbH & Co. KG**

Hauptstr. 76  
D-37083 Göttingen  
Tel.: (0551) 79001-0  
Fax: (0551) 79001-65  
email: Info@ThiesClima.com

Description of Product: **Brightness Transmitter**

Article No.	7.1414.10.003	7.1414.10.040	7.1414.10.041	7.1414.10.061
	7.1414.10.541	7.1414.10.561	7.1414.10.941	7.1414.12.040
	7.1414.12.041	7.1414.12.061	7.1414.15.040	7.1414.15.041
	7.1414.15.061	7.1414.22.040	7.1414.22.041	7.1414.22.061
	7.1414.25.040	7.1414.25.041	7.1414.25.061	7.1414.40.002
	7.1414.40.102	7.1414.40.103	7.1414.40.112	7.1414.40.141
	7.1414.40.152	7.1414.51.150	7.1414.51.550	
	7.1414.60.000	7.1414.60.040	7.1414.60.041	7.1414.60.500
	7.1414.61.000	7.1414.61.040	7.1414.61.041	

specified technical data in the document: **020923/05/07; 021316/05/07; 021327/05/10; 021524/05/07; 021458/04/11; 021601/12/09; 021630/02/10**

The indicated products correspond to the essential requirement of the following European Directives and Regulations:

2004/108/EC	DIRECTIVE 2004/108/EC OF THE EUROPEAN PARLIAMENT AND OF THE COUNCIL of 15 December 2004 on the approximation of the laws of the Member States relating to electromagnetic compatibility and repealing Directive 89/336/EEC
2006/95/EC	DIRECTIVE 2006/95/EC OF THE EUROPEAN PARLIAMENT AND OF THE COUNCIL of 12 December 2006 on the harmonisation of the laws of Member States relating to electrical equipment designed for use within certain voltage limits
552/2004/EC	Regulation (EC) No 552/2004 of the European Parliament and the Council of 10 March 2004 on the interoperability of the European Air Traffic Management network (the interoperability Regulation)

The indicated products comply with the regulations of the directives. This is proved by the compliance with the following standards:

Reference number	Specification
IEC 61000-6-2: 2005	Electromagnetic compatibility Immunity for industrial environment
IEC 61000-6-3: 2006	Electromagnetic compatibility Emission standard for residential, commercial and light industrial environments
IEC 61010-1: 2001	Safety requirements for electrical equipment for measurement, control and laboratory use. Part 1: General requirements

Place: Göttingen

Date: 21.04.2011

Legally binding signature:

issuer:

.....  
Wolfgang Behrens, General Manager

.....  
Joachim Beinhorn, Development Manager

This declaration certifies the compliance with the mentioned directives, however does not include any warranty of characteristics. Please pay attention to the security advises of the provided instructions for use.





## **ADOLF THIES GmbH & Co. KG**

Hauptstraße 76 37083 Göttingen Germany  
P.O. Box 3536 + 3541 37025 Göttingen  
Phone +49 551 79001-0 Fax +49 551 79001-65  
www.thiesclima.com info@thiesclima.com



- Alterations reserved -