



—
your partner
in sensor
technology.



User Manual EE431

Duct and Immersion Temperature Sensor



Content

1	General Information	3
1.1	Explanation of Warning Notices and Symbols	3
1.2	Safety Instructions	4
1.2.1.	General Safety Instructions	4
1.2.2.	Intended Use	4
1.2.3.	Mounting, Start-up and Operation	4
1.3	Environmental Aspects	5
2	Scope of Supply	5
3	Product Description	6
3.1	General	6
3.2	Dimensions	6
3.2.1.	EE431 Duct and Immersion Temperature Sensor	6
3.3	Electrical Connection	7
3.3.1.	Wiring for Active Models	7
3.3.2.	Wiring Diagram for Models with Passive T output	9
3.4	Display	9
4	Mounting and Installation	9
4.1	Duct Mounting	10
4.1.1.	Mounting with flange	10
4.1.2.	Minimum Immersion Depth	10
4.1.3.	Mounting with Immersion Well	10
4.1.4.	Maximum Inflow Velocity on the Immersion Well	11
5	Setup and Configuration	11
5.1	Software	12
5.1.1.	EE-PCS Product Configuration Software	12
5.1.2.	PCS10 Product Configuration Software	12
5.2	EE431 analogue with HA011023	12
5.3	EE431 analogue with EE-PCA and HA011065	12
5.4	EE431 with RS485 Digital Interface and HA011070	13
5.4.1.	Hardware Bus Termination	13
5.4.2.	Device Address	13
5.4.3.	Modbus RTU Protocol Settings	13
5.4.4.	Modbus Register Map	15
5.4.5.	Modbus RTU Example	15
6	Maintenance and Service	16
6.1	Calibration and Adjustment	16
6.1.1.	Definitions	16
6.1.2.	Temperature Calibration and Adjustment	16
6.1.3.	Calibration and Adjustment at E+E Elektronik	16
6.1.4.	Calibration and Adjustment by the User	16
6.2	Repairs and Display Change	17
7	Accessories	18
8	Technical Data	19
9	Conformity	22
9.1	Declarations of Conformity	22
9.2	Electromagnetic Compatibility	22
9.3	UL Compliance Statement	22
9.4	FCC Part 15 Compliance Statement	22
9.5	ICES-003 Compliance Statement	22

1 General Information

This user manual is intended to ensure proper handling and optimal functioning of the device. The user manual shall be read before commissioning the equipment and it shall be provided to all staff involved in transport, installation, operation, maintenance and repair. E+E Elektronik Ges.m.b.H. accepts no liability for any warranty or liability claims arising from this publication or improper handling of the product(s) described.

All information, technical data and diagrams included in this document are based on the information available at the time of writing. The document may contain technical inaccuracies and typographical errors. The contents will be revised on a regular basis and changes will be implemented in subsequent versions. The product(s) described and the contents of this document may be changed or improved at any time without prior notice.

All rights are reserved by E+E Elektronik Ges.m.b.H. No part of this document may be reproduced, published or publicly displayed in any form or by any means, nor may its contents be modified, translated, adapted, sold or disclosed to a third party without prior written permission of E+E Elektronik Ges.m.b.H.

PLEASE NOTE

Find this document and further product information on our website at www.epluse.com/ee431.

1.1 Explanation of Warning Notices and Symbols

Safety precautions

Precautionary statements warn of hazards in handling the device and provide information on their prevention. The safety instruction labeling is classified by hazard severity and is divided into the following groups:

DANGER

Danger indicates hazards for persons. If the safety instruction marked in this way is not followed, the hazard will very likely result in severe injury or death.

WARNING

Warning indicates hazards for persons. If the safety instruction marked in this way is not followed, there is a risk of injury or death.

CAUTION

Caution indicates hazards for persons. If the safety instruction marked in this way is not followed, minor or moderate injuries may occur.

NOTICE

Notice signals danger to objects or data. If the notice is not observed, damage to property or data may occur.

Informative notes

Informative notes provide important information that is characterised by its relevance.

INFO

The information symbol indicates tips on handling the device or provides additional information on it. This information is useful to achieve optimum performance of the device.

The title field may deviate from "INFO" depending on the context. For instance, it may also read "PLEASE NOTE".

1.2 Safety Instructions

1.2.1. General Safety Instructions

NOTICE

Improper handling of the device may result in its damage.

- Avoid any unnecessary mechanical stress and inappropriate use.
- Only qualified personnel shall carry out installation, electrical connection, maintenance and commissioning of the equipment.
- Use the temperature sensors only as intended and observe all technical specifications.
- The device is designed for operation with class III supply (EU) and class 2 supply (NA).
- Do not apply the supply voltage to the RS485 data lines.

1.2.2. Intended Use

The EE431 duct and immersion temperature sensor is optimised for reliable and accurate temperature monitoring in air and liquids within the specified temperature range (refer to datasheet www.epluse.com/ee431).

Typical applications for the sensor are:

- Building automation
- HVAC
- Process control

Apply the mounting and installation methods described in chapter 4 Mounting and Installation.

WARNING

Non-compliance with the product documentation may cause safety risks for people and the entire measurement installation.

The manufacturer is not liable for any damage caused by improper handling, installation and maintenance of the device.

- Never use the EE431 in explosive atmosphere or for measurement in aggressive gases.
- This device is not appropriate for safety, emergency stop or other critical applications where device malfunction or failure could cause injury to human beings.
- Use only the tools specified in this manual when manipulating the device.

NOTICE

Failure to follow the instructions in this user manual may lead to measurement inaccuracy and device failures.

- The EE431 may only be operated under the conditions described in this user manual and within the specification included in chapter 8 Technical Data.
- Any unauthorised product modification will invalidate all warranty claims. Modifications may only be carried out with the express authorisation of E+E Elektronik Ges.m.b.H.!

1.2.3. Mounting, Start-up and Operation

The EE431 has been produced under state of the art manufacturing conditions, has been thoroughly tested and has left the factory after fulfilling all safety criteria. The manufacturer has taken all precautions to ensure safe operation of the device. The device shall be set up and installed in a way that does not impair its safe use. All applicable local and international safety guidelines for safe installation and operation of the device have to be observed. This user manual contains information and warnings that must be observed in order to ensure safe operation.

i PLEASE NOTE

The manufacturer or his authorised agent can only be held liable in case of willful or gross negligence. In any case, the scope of liability is limited to the corresponding amount of the order issued to the manufacturer. The manufacturer assumes no liability for damage caused by non-compliance with the applicable regulations, operating instructions or the specified operating conditions. Any consequential damage is excluded from liability.

⚠ WARNING

Non-compliance with the product documentation may result in accidents, personal injury or property damage.

- Mounting, installation, commissioning, start-up, operation and maintenance of the device may only be carried out by qualified staff. Such staff must be authorised by the operator of the facility to carry out the mentioned activities.
- The qualified staff must have read and understood this user manual and must follow the instructions contained within. The manufacturer accepts no responsibility for non-compliance with instructions, recommendations and warnings.
- All process and electrical connections must be thoroughly checked by authorised staff before commissioning the device.
- Do not install or start-up a device suspected to be faulty. Mark it clearly as faulty and remove it from the process.
- Service operations other than described in this user manual may only be performed by the manufacturer. A faulty device may only be investigated and possibly repaired by qualified, trained and authorised staff. If the fault cannot be fixed, the device shall be removed from the process.

1.3 Environmental Aspects

i PLEASE NOTE

Products from E+E Elektronik Ges.m.b.H. are developed and manufactured in compliance with all relevant environmental protection requirements. Please observe local regulations for the disposal of the device.



For disposal, the individual components of the device must be separated according to local recycling regulations. The electronics shall be disposed of correctly as electronics waste.

2 Scope of Supply

- Temperature sensor
- Test report according to DIN EN10204-2.2 (for active output only)
- Quick guide (digital interface only)
- Cable gland

3 Product Description

3.1 General

The EE431 duct and immersion sensor reliably measures the temperature (T) in air and liquids. It is optimised for building automation, HVAC and process control. The measured data is available at the voltage or current output, on the RS485 interface with Modbus RTU protocol and on the optional display. The analogue output can be set to °C or °F. In addition, the EE431 features a wide choice of sensing elements for passive temperature measurement.

3.2 Dimensions

3.2.1. EE431 Duct and Immersion Temperature Sensor

Values in mm (inch)

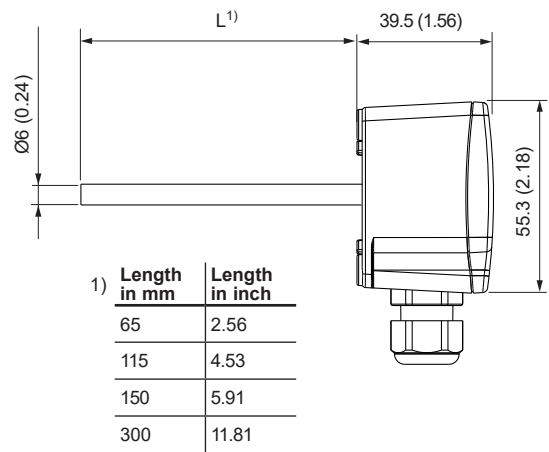
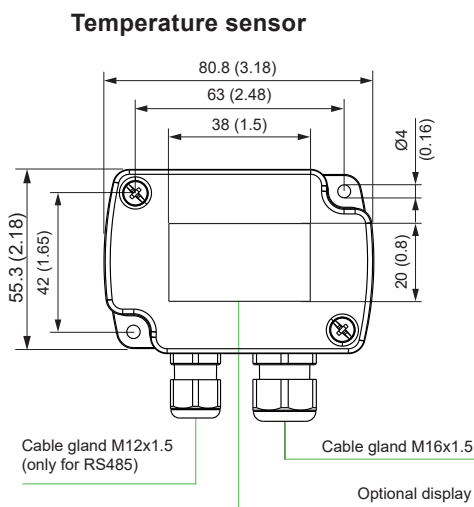

Mounting accessories

Mounting flange

(not included in the scope of supply)

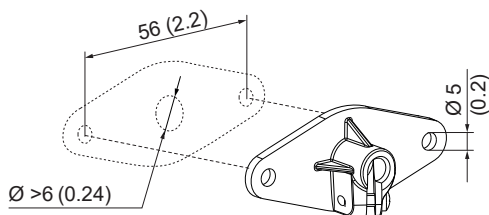

Immersion well

(not included in the scope of supply)

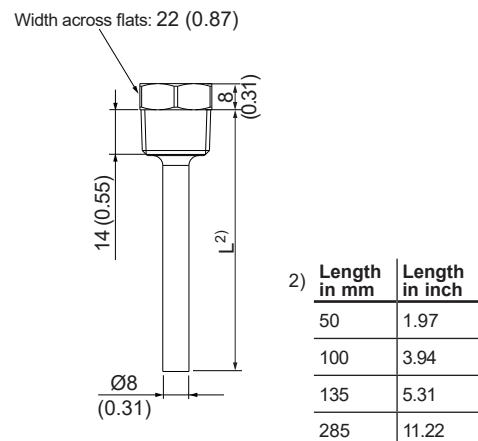

3.3 Electrical Connection

⚠ WARNING

Incorrect installation, wiring or power supply may cause overheating and result in personal injury or property damage.

Cables must not be under voltage during electrical installation and during connection or disconnection, especially at terminal connections on circuit boards. For correct cabling, always observe the presented wiring diagram for the product version used.

The manufacturer cannot be held responsible for personal injury or damage to property caused by incorrect handling, installation, wiring, power supply or maintenance of the device

The EE431 is equipped with screw terminals for easy connection of the power supply and the outputs. Route the cables into the enclosure through the M16 cable gland.

NOTICE

Ensure that the cable glands for the power supply and output cables are tightened securely. This is required to maintain the enclosure's IP rating according to the EE431 specification and to provide proper stress relief for the screw terminals on the EE431 board.

3.3.1. Wiring for Active Models

Models with analogue output (0 – 10V)

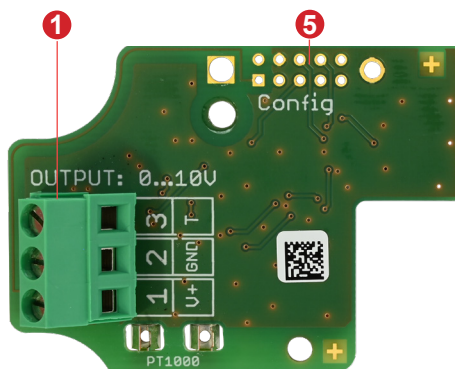
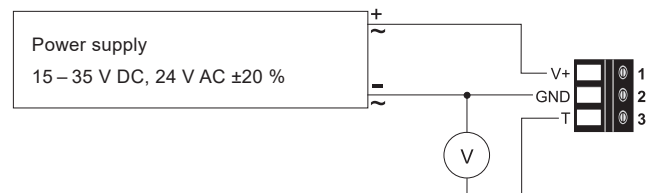
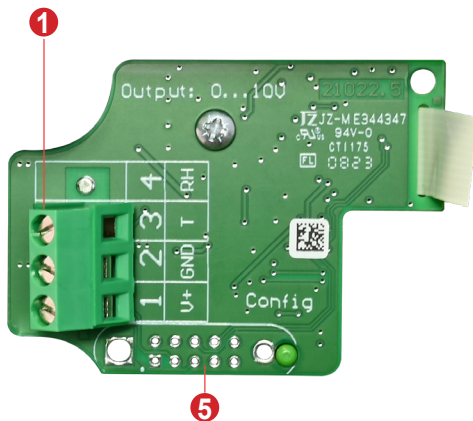

Models with analogue output (4 – 20mA)

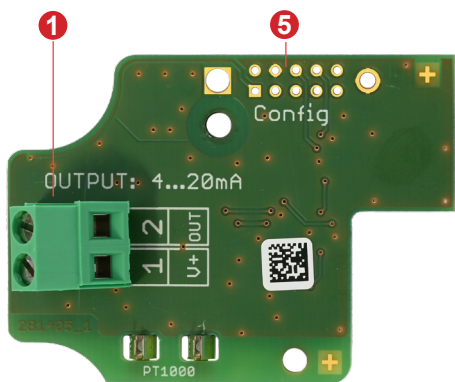
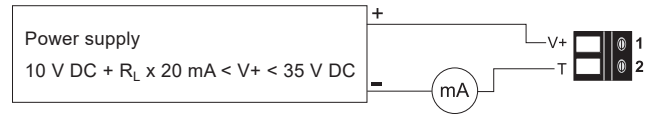
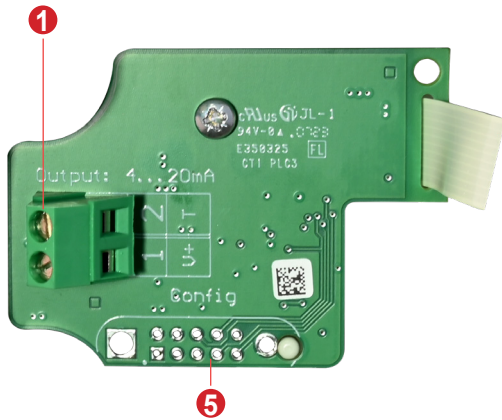

Models with digital interface

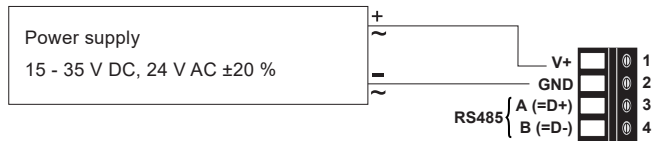
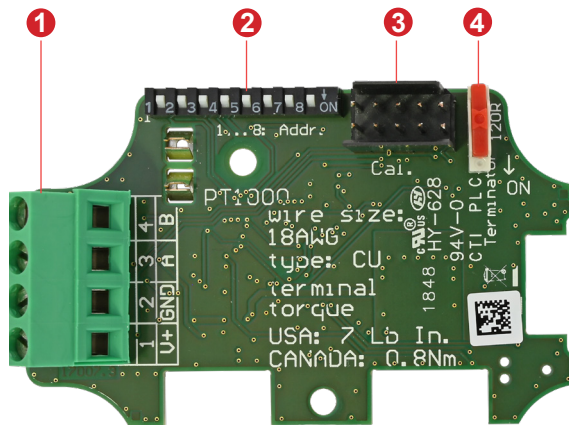

Fig. 1 Temperature sensor connection options

No.	Function
1	Screw terminals for power supply and outputs
2	Address DIP switch for RS485 interface
3	Configuration connector (USB-C configuration stick) for RS485 interface
4	Bus termination resistor 120 Ω (jumper)
5	Configuration connector for analogue version

Tab. 1 Part of the digital temperature sensor electronics board types

3.3.2. Wiring Diagram for Models with Passive T output

The unit wiring diagram applies to all passive types. The connections can be interchanged.

2-wire connection



Fig. 2 Temperature sensor connection for passive models

3.4 Display

The single-line LC (Liquid Crystal) display is only available for the active models with analogue output (according to ordering code, see datasheet www.epluse.com/ee431).

Depending on the order code, the measured data is displayed in °C or °F. The displayed unit can be changed with the free PCS10 Product Configuration Software, refer to chapter 5 Setup and Configuration for further details.



EE431 set for °F



EE431 set for °C

4 Mounting and Installation

NOTICE

Improper handling of the device may result in its damage.

- Assembly and installation may only be carried out by qualified personnel.

NOTICE

Failing to follow the instructions in this user manual may lead to measurement inaccuracy and device failures.

- For accurate measurements, ensure that the sensor has reached the same temperature as the air being measured.
- Mount the temperature sensor at representative locations of the space to be monitored (see Fig. 4 and Fig. 5).
- Avoid exposing the sensor to extreme mechanical stress.

For best accuracy please observe the general mounting instructions and recommended mounting positions outlined in the subchapters below.

4.1 Duct Mounting

4.1.1. Mounting with flange

- Mount the sensor approximately one meter from the inlet
- Install the probe so that the tip is placed at the centre of the duct

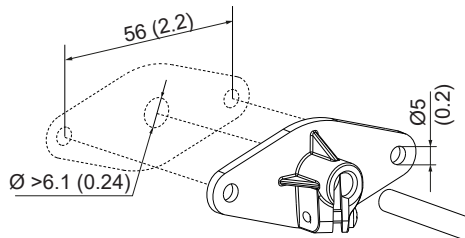

Fig. 3 Correct position of the probe in a flange

4.1.2. Minimum Immersion Depth

Placement options

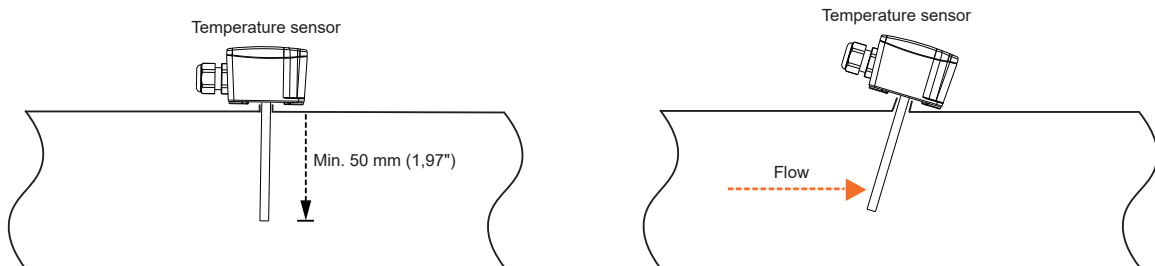

Fig. 4 Correct position in a pipe

4.1.3. Mounting with Immersion Well

i PLEASE NOTE

- Avoid installing the sensor in regions with strong turbulence (e.g. directly after fittings)
- Mount the sensor facing opposite to the flow direction (see “Correct Position” below)

Correct Position

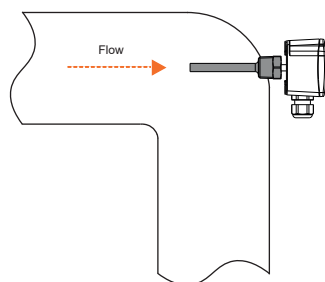

Incorrect Position

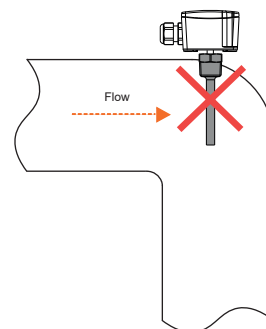

Fig. 5 Probe position in the pipe with immersion well

4.1.4. Maximum Inflow Velocity on the Immersion Well

Immersion Well Length	Brass	Stainless Steel
50 mm (1.97")	26 m/s (5118 ft/min)	29 m/s (5708 ft/min)
100 mm (3.94")	12 m/s (2362 ft/min)	15 m/s (2953 ft/min)
135 mm (5.31")	6 m/s (1181 ft/min)	9 m/s (1771 ft/min)
285 mm (11.22")	1 m/s (197 ft/min)	2 m/s (394 ft/min)

Tab. 2 Maximal inflow velocity

5 Setup and Configuration

The temperature sensor is ready to use and does not require any further configuration. The factory setup corresponds to the specified order code. For ordering guide please refer to the datasheet at www.epluse.com/ee431.

If needed, the factory setup can be modified using the free Product Configuration Software and the appropriate accessories (see Tab. 3 Configuration accessories).

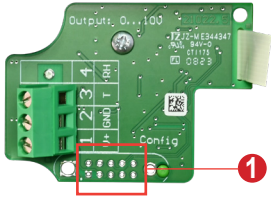
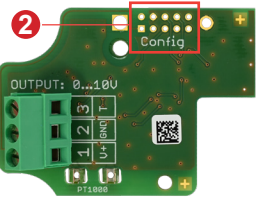
Sensor Models		Configuration with	
		EE-PCS	PCS10
Analogue 0 – 10 V / 4 – 20 mA			HA011023
Analogue 0 – 10 V / 4 – 20 mA		EE-PCA with HA011065	
Digital version	EE431-M3J3	HA011070	

Tab. 3 Configuration accessories

No.	Description
1	Plug in the configuration adapter at the bottom
2	Plug in the configuration adapter on the top

Tab. 4 Positioning of the configuration adapter

5.1 Software

5.1.1. EE-PCS Product Configuration Software

Use the software to perform adjustments and changes in the settings and proceed as follows:

1. Download the EE-PCS Product Configuration Software from www.epluse.com/configurator and install it on a PC.
2. Connect the EE431 to the PC using the appropriate configuration adapter.
3. Start the EE-PCS software.
4. Follow the instructions on the EE-PCS opening page to scan the ports and to identify the connected device.
5. Click on the desired setup or adjustment mode from the main EE-PCS menu on the left. Follow the EE-PCS online instructions.

5.1.2. PCS10 Product Configuration Software

Use the software to perform adjustments and changes in the settings and proceed as follows:

1. Download the PCS10 Product Configuration Software from www.epluse.com/pcs10 and install it on a PC.
2. Connect the EE431 to the PC using the USB configuration adapter.
3. Start the PCS10 software.
4. Follow the instructions on the PCS10 opening page to scan the ports and to identify the connected device.
5. Click on the desired setup or adjustment mode from the main PCS10 menu on the left. Follow the PCS10 online instructions that are displayed when clicking on the “Tutorial” button.
6. Upload changes to the sensor by pressing the “Sync” button.

5.2 EE431 analogue with HA011023

Use the PCS10 together with the HA011023 USB configuration adapter to configure the EE431 with analogue output. An external power supply in accordance with the technical data is required. The V03 power supply adapter is suitable for this purpose. As soon as the device is connected to the adapter, the display shows “CAL”.

With the PCS10, the output scaling, the output measuring unit and the displayed unit (°C or °F) can be changed.

Upper and lower thresholds can be set up for the measurands. The display flashes at one-second interval for measured T beyond the range.

An offset adjustment (Fig. 10) and a 1- or 2-point adjustment (Fig. 11) can be performed, as well as a reset to factory adjustment and factory settings. Besides, the configuration settings can also be exported or imported.

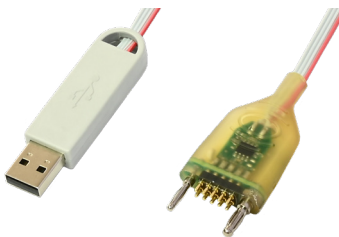

Fig. 6 HA011023 USB configuration adapter for EE431 with analogue output

5.3 EE431 analogue with EE-PCA and HA011065

Use the EE-PCS together with the EE-PCA and the HA011065 connection cable. For further details, refer to the EE-PCA datasheet (available at www.epluse.com/ee431).

With the PCS10, the output scaling, the output measuring unit, and the displayed unit (°C or °F) can be changed.

An offset adjustment (Fig. 10) and a 1- or 2-point adjustment (Fig. 11) can be performed, as well as a reset to the factory adjustment and factory settings. In addition, the configuration settings can also be exported or imported.

5.4 EE431 with RS485 Digital Interface and HA011070

Use the EE-PCS together with the USB-C configuration stick HA011070.

NOTICE

The USB-C configuration stick HA011070 galvanically isolates the USB interface of the PC from the supply voltage of the EE431. When using the USB-C configuration stick the EE431 needs external supply.

The former configuration adapter cable HA011066 remains fully compatible with the EE431 equipped with a digital interface.

Using EE-PCS, an offset adjustment (see Fig. 10) as well as a 1- or 2-point adjustment (see Fig. 11) can be performed. The temperature adjustment can also be reset to factory settings. In addition, further digital configuration settings can be made (see sections below).

5.4.1. Hardware Bus Termination

The bus termination can be realised with 120 Ω resistor (slide switch on the board).

5.4.2. Device Address

Address Switch



Address setting via EE-PCS Product Configuration Software

All DIP switches at position 0 → address has to be set via EE-PCS (= *factory setting*).

Modbus (slave device):

Factory setting 66 (permitted values: 1...247).

Example: 0000 0000 = Address is set via configuration software.

Address Switch

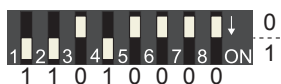

Address setting via DIP switch

Modbus (slave device): Setting the DIP switches to any other address than 0, overrules the Modbus address set via EE-PCS (permitted values: 1...247).

Example: 0000 1011 binary = Address set to 11.

5.4.3. Modbus RTU Protocol Settings

	Factory settings	User selectable values (via EE-PCS / Modbus protocol)
Baud rate	As per type number ordered	9 600, 19 200, 38 400
Data bits	8	8
Parity	Even	None, odd, even
Stop bits	1	1, 2
Modbus address	66	1...247

Tab. 5 Modbus RTU protocol settings

i PLEASE NOTE

- The recommended settings for multiple devices in a Modbus RTU network are 9 600, 8, even, 1.
- The EE431 represents 1 unit load on an RS485 network.

Device address, baud rate, parity and stop bits can be set via:

- EE-PCS Product Configuration Software and the USB-C configuration stick HA011070.
The EE-PCS can be downloaded free of charge from www.epluse.com/configurator.
- Modbus protocol in the register 1 (0x00) and 2 (0x01).
See Application Note Modbus AN0103 (available at www.epluse.com/ee431).

The measured values are saved as 32 bit float value (FLOAT32) and 16 bit signed integer (INT16). The factory setting for the Modbus address is 66 as an INT16 value. This address can be changed by the user in the register 1 (0x00), permitted values are 1...247.

The serial number as ASCII-code is located in read-only registers 1 - 8 (0x00 - 0x07, 16 bits per register). The firmware version is located in register 9 (0x08) (bit 15...8 = major release; bit 7...0 = minor release). The sensor name as ASCII-code is located in read-only registers 10 - 17 (0x09 - 0x10, 16 bits per register).

NOTICE

When reading the serial number or the sensor name, it is always necessary to read all 8 registers, even if the desired information requires less.

NOTICE

To obtain the correct floating point values, both registers have to be read within the same reading cycle. The measured value may change between two Modbus requests. This can cause inconsistencies in the exponent and mantissa.

INFO

The Modbus function codes mentioned throughout this document shall be used as described in chapter 6 of [MODBUS APPLICATION PROTOCOL SPECIFICATION V1.1b3](https://www.modbus.org/), available at <https://www.modbus.org/>.

Communication settings (INT16)

Parameter	Register number ¹⁾ [Dec]	Register address ²⁾ [Hex]	Size ³⁾
Write register: function code 0x06			
Modbus address ⁴⁾	1	00	1
Modbus protocol settings ⁵⁾	2	01	1

Device information (INT16)

Parameter	Register number ¹⁾ [Dec]	Register address ²⁾ [Hex]	Size ³⁾
Read register: function code 0x03 / 0x04			
Serial number (as ASCII)	1	00	8
Firmware version	9	08	1
Sensor name (as ASCII)	10	09	8

1) Register number (decimal) starts from 1.

2) Protocol address (hexadecimal) starts from 0.

3) Number of registers.

4) If the address is set via DIP switch, the response will be NAK.

5) For Modbus address and protocol settings see Application Note Modbus AN0103 (available at www.epluse.com/ee431).

Tab. 6 Digital sensors' registers for device setup

5.4.4. Modbus Register Map

The measured data is stored as 32 bit floating point values (FLOAT32) and as 16 bit signed integer values (INT16).

FLOAT32

Measurand	Unit ¹⁾	Register number ²⁾ [DEC]	Register address ³⁾ [HEX]
Read register: function code 0x03 / 0x04			
Temperature	°C	1003	3EA
	°F	1005	3EC
	°K	1009	3F0

INT16

Measurand	Unit ¹⁾	Scale ⁴⁾	Register number ²⁾ [DEC]	Register address ³⁾ [HEX]
Read register: function code 0x03 / 0x04				
Temperature	°C	100	4002	FA1
	°F	50	4003	FA2
	K	50	4005	FA4

- 1) The choice of measurement units (metric or non-metric) must be done according to the ordering guide, see EE431 datasheet. Switching from metric to non-metric or vice versa by using the EE-PCS is not possible.
- 2) Register number (decimal) starts from 1.
- 3) Register address (hexadecimal) starts from 0.
- 4) Examples: For scale 100, the reading of 2550 means a value of 25.5. For scale 50, the reading of 2550 means a value of 51.

Tab. 7 EE431 FLOAT32 and INT16 measured data registers

5.4.5. Modbus RTU Example

The EE431's Modbus address is 66 [0x42].

Please refer to

- Chapter 6 of [MODBUS APPLICATION PROTOCOL SPECIFICATION V1.1b3](https://www.modbus.org/), available at <https://www.modbus.org/>.
- E+E Application Note Modbus AN0103 (available at www.epluse.com/ee431)

Read the temperature (FLOAT32) T = 26.953624725341796875 °C from register address 0x3EA:

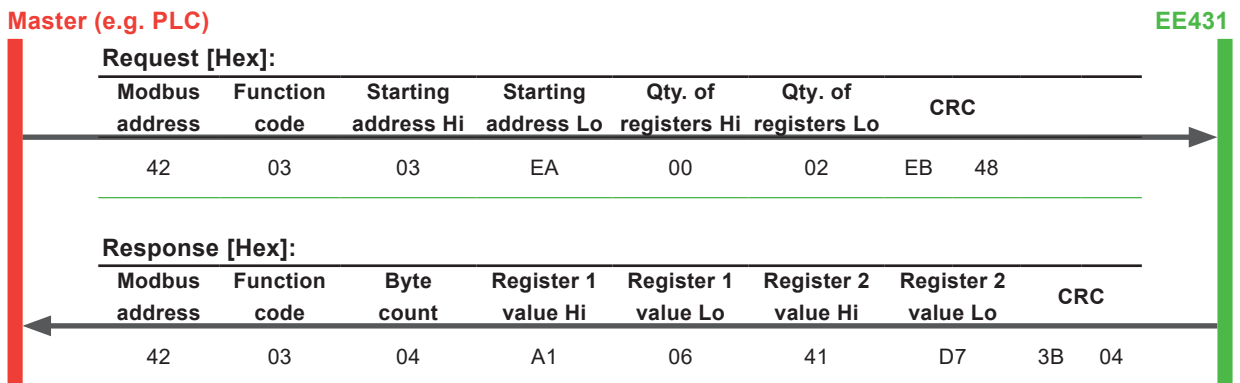

Fig. 7 Example temperature query

Decoding of floating point values:

Floating point values are stored according to IEEE754. The byte pairs [1], [2] and [3], [4] are transformed as follows (numbers taken from T reading Modbus request/response example, Fig. 7):

Modbus response [Hex]			
Register 1 Hi [3]	Register 1 Lo [4]	Register 2 Hi [1]	Register 2 Lo [2]
A1	06	41	D7
MMMM MMMM	MMMM MMMM	SEEE EEEE	EMMM MMMM

Fig. 8 Modbus response

IEEE754			
Register 2 Hi [1]	Register 2 Lo [2]	Register 1 Hi [3]	Register 1 Lo [4]
41	D7	A1	06
0100 0001	1101 0111	1010 0001	0000 0110
SEEE EEEE	EMMM MMMM	MMMM MMMM	MMMM MMMM
Decimal value: 26.953624725341796875			

Fig. 9 Data representation according to IEEE754

6 Maintenance and Service

6.1 Calibration and Adjustment

6.1.1. Definitions

Calibration documents the accuracy of a measurement device. The device under test (specimen) is compared with the reference and the deviations are documented in a calibration certificate. During the calibration, the specimen is not changed or improved in any way.

Adjustment improves the measurement accuracy of a device. The specimen is compared with the reference and brought in line with it. An adjustment can be followed by a calibration which documents the accuracy of the adjusted specimen.

6.1.2. Temperature Calibration and Adjustment

Depending on the application and the requirements of certain industries, there might arise the need for periodical temperature calibration or adjustment.

6.1.3. Calibration and Adjustment at E+E Elektronik

Calibration and/or adjustment can be performed in the E+E Elektronik calibration laboratory. For information on the E+E capabilities in ISO or accredited calibration please see www.eplusecal.com and www.epluse.com/iso9001cal

6.1.4. Calibration and Adjustment by the User

Depending on the level of accuracy required, the temperature reference can be:

- Liquid bath calibrator
- Dry block calibrator
- Climate chamber
- Handheld device (e.g. Omniport 40), please see www.epluse.com/omniport40.

Perform an offset adjustment and an 1- or 2-point adjustment via the E+E Product Configuration Software (see below).

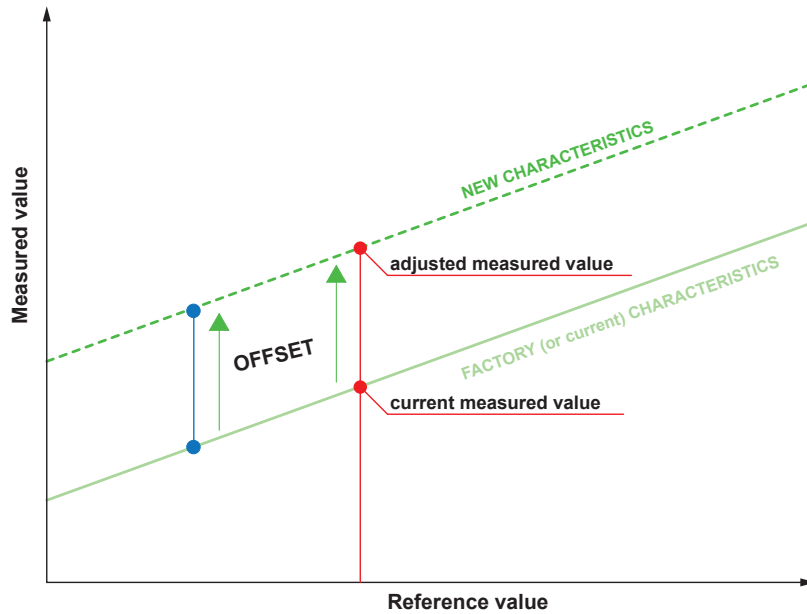

Fig. 10 Offset adjustment

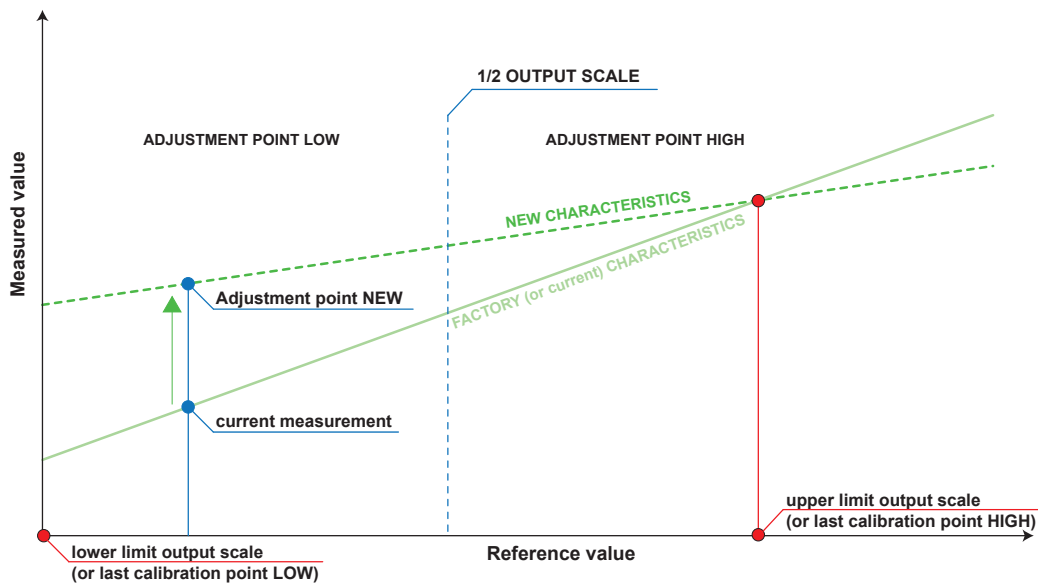

Fig. 11 1- or 2-point adjustment

6.2 Repairs and Display Change

i PLEASE NOTE

Repairs may be carried out by the manufacturer only. The attempt of unauthorised repair will invalidate any warranty claims.

7 Accessories

For further information see datasheet [Accessories](#).

Description		Code			
USB configuration adapter for display and 0 – 10 V versions without display		HA011023			
USB-C configuration stick for digital version		HA011070			
E+E Product Configuration Software for digital output and for 4 – 20 mA version without display (Free download: www.epluse.com/configurator)		EE-PCS			
E+E Product Configuration Software (Free download: www.epluse.com/pcs10) for display and 0 – 10 V versions without display		PCS10			
Power supply adapter 24 V DC for digital output		V03			
Conduit Adapter US, M16x1.5 - 1/2", plastic		HA011110			
Plastic mounting flange for probes with Ø6 mm (0.24"), with alignment notch		HA401101			
Immersion well - thread R ½" ISO	Length in mm (inch)	50 (1.97")	100 (3.94")	135 (5.31")	285 (11.22")
	Brass	HA400101	HA400104	HA400102	HA400103
	Stainless steel	HA400201	HA400204	HA400202	HA400203
Immersion well - thread ½" NPT	Length in mm (inch)	50 (1.97")	100 (3.94")	135 (5.31")	285 (11.22")
	Brass	HA400111	HA400114	HA400112	HA400113
	Stainless steel	HA400211	HA400214	HA400212	HA400213

8 Technical Data

Measurands

Temperature (T) - Active

Measuring range	Duct sensor (probe tip)	-40 °C...+110 °C (-40...+230 °F)
	With immersion well (probe tip)	-40 °C...+130 °C (-40...+266 °F)
Accuracy @ 20 °C (68 °F)		±0.25 °C (±0.36 °F)
	Optional for analogue output	±0.1 °C (±0.18 °F) ¹⁾

1) Uncertainty of factory calibration at 20 °C ±0.1 °C (68 °F ±0.18 °F).

Temperature (T) - Passive

Measuring range	Duct sensor	-40 °C...+110 °C (-40...+230 °F)		
	Immersion Sensor with Pt and Ni T sensor	-40 °C...+150 °C (-40...+302 °F)		
Sensor type		Nominal resistance	Sensitivity	Standard
	Pt100 DIN B	R ₀ : 100 Ω	TC: 3.850 x 10 ⁻³ /°C	DIN EN 60751
	Pt1000 DIN B	R ₀ : 1000 Ω	TC: 3.850 x 10 ⁻³ /°C	DIN EN 60751
	NTC10k B3950	R ₂₅ : 10 kΩ ±0.5 %	B _{25/85} : 3989 K (B _{25/50} : 3950 K ± 1.0 %)	-
	NTC20k B4286	R ₂₅ : 20 kΩ ± 0.2 °C	B _{25/85} : 4286 K (B _{25/85} : 4286 K ± 1.0 %)	-
	Ni1000 TK5000 DIN B	R ₀ : 1000 Ω	TC: 5000 ppm/K	DIN 43760

Outputs

Analogue

Analogue output	0 – 10 V 4 – 20 mA (2-wire)	-1mA < I _L < 1 mA R _L ≤ 500 Ω	I _L = load current R _L = load resistance
------------------------	--------------------------------	--	---





Digital

Digital interface	RS485 (EE431 = 1 Unit Load)
Protocol Factory settings Supported Baud rates Measured data types	Modbus RTU Baud rate see order information, data bits 8, parity even, 1 stop bit, Modbus address 66 9 600, 19 200 und 38 400 FLOAT32 and INT16

T Sensor Passive

Sensor connection	2-wire connection
Measuring current, typ.	<1 mA (according to technical data of the specific T sensing element)

General

Power supply class III  USA & Canada: Class 2 supply necessary, max. voltage 30 V DC for output RS485 and 0 – 10 V for output 4 – 20 mA		15 – 35 V DC or 24 V AC $\pm 20\%$ 10 V DC + $R_L \times 20 \text{ mA} < V < 35 \text{ V DC}$ $R_L = \text{load resistance}$				
Current consumption, @ 24 V	Voltage output	DC supply max. 1.2 mA AC supply max. 4.6 mA _{rms}	with display max. 2.1 mA with display max. 7 mA _{rms}			
	Current output	According to output current	According to output current			
	Digital interface	DC supply typ. 3.5 mA AC supply typ. 12 mA _{rms}				
Electrical connection		Screw terminals max. 2.5 mm ² (AWG14)				
Cable glands		M16x1.5 / M12x1.5 / UL94 V-2				
Insulation resistance (probe) @20 °C (68 °F)		>100 MΩ				
LC-display		Available for output A3 and A6 1 line, switchable between °C / °F or according to order code Without backlight Visible area 38 mm x 20 mm (1.5" x 0.8")				
Response time t₆₃ Duct sensor at 3 m/s (590 ft/min) air velocity Immersion sensor in liquid water bath		<1 min <30 s				
Humidity working range		5...95 %RH, non-condensing				
Temperature working range		Duct sensor (probe tip)	With immersion well (probe tip) Active Passive	Electronics without Display	Electronics with Display	
		-40...+110 °C (-40...+230 °F)	-40...+130 °C (-40...+266 °F)	-40 °C...+150 °C (-40...+302 °F)	-40...+70 °C (-40...+158 °F)	-20...+50 °C (-4...+122 °F)
Storage conditions	Without display	-30...+70 °C (-22...+158 °F) 5...95 %RH, non-condensing				
	With display	-20...+50 °C (-4...+122 °F) 5...95 %RH, non-condensing				
Probe material		Stainless steel (1.4571 / 316Ti)				
Enclosure	Material	Polycarbonate (PC), UL94 V-0 approved				
	Protection rating	IP65 NEMA 4X – not UL approved				
Electromagnetic compatibility		EN 61326-1 FCC Part15 Class A	EN 61326-2-3 ICES-003 Class A	Industrial environment		
Conformity		 				
UL compliance statement¹⁾		 UL Compliance Statement United States UL Listed, CCN QUYX, Under UL 61010-1, Process Control Equipment; FCC Compliant to CFR47, Part 15, Subpart B, Class A Canada UL Listed, CCN QUYX7, Under CSA C22.2 No. 61010-1, Signal Equipment; Industry Canada Compliant, ICES-003				
Configuration and adjustment For 0 – 10 V version and 4 – 20 mA version		PCS10 Product Configuration Software (free download: www.epluse.com/pcs10) and configuration adapter.				
	For digital version	EE-PCS Product Configuration Software (free download: www.epluse.com/configurator) and USB-C configuration stick.				

1) Only for EE431-M3A6 Versions.

Accuracy of E+E Temperature Sensors

The measurement accuracy depends both on the performance of the measuring instrument and on the correct installation in the application.

For best accuracy, E+E T sensors are factory adjusted and calibrated in a highly stable T reactor. Using a high-precision T reference, the overall uncertainty of the factory calibration U_{cal} is minimal.

The total measurement uncertainty U_{total} for E+E sensors is calculated in accordance with EA-4/02 (European Accreditation, Evaluation of the Measurement Uncertainty in Calibration) and with GUM (Guide to the Expression of Uncertainty in Measurement) as follows:

$$U_{\text{total}} = k \cdot \sqrt{\left(\frac{U_{\text{cal}}}{2}\right)^2 + \left(\frac{u_{\text{accuracy}}}{\sqrt{3}}\right)^2}$$

U_{total} total accuracy incl. factory calibration

U_{cal} the uncertainty of the factory calibration

u_{accuracy} ...the accuracy of the measurement device

kcoverage factor $k=2$, corresponding to a confidence level of 95 %.

For external calibrations, U_{total} is to be used as the evaluation criterion. The calculation does not include effects due to long-term drift or chemical exposure.

As designated laboratory (NMI) responsible for maintaining the National Standard for humidity and temperature in Austria, E+E Elektronik represents the highest instance in humidity and temperature calibration.

9 Conformity

9.1 Declarations of Conformity

E+E Elektronik Ges.m.b.H. hereby declares that the product complies with the respective regulations listed below:



European directives and standards.

and



UK statutory instruments and designated standards.

Please refer to the product page at www.epluse.com/ee431 for the Declarations of Conformity.

9.2 Electromagnetic Compatibility

EMC for industrial environment.

The sensor is a group 1 device and corresponds to Class A.

WARNING

This device is not intended for use in residential areas and cannot ensure adequate protection of radio reception in such environments.

9.3 UL Compliance Statement



United States

UL Listed, CCN QUYX, Under UL 61010-1, Process Control Equipment;
FCC Compliant to CFR47, Part 15, Subpart B, Class A

Canada

UL Listed, CCN QUYX7, Under CSA C22.2 No. 61010-1, Signal Equipment;
Industry Canada Compliant, ICES-003

9.4 FCC Part 15 Compliance Statement

This equipment has been tested and found to comply with the limits for a Class A digital device, pursuant to part 15 of the FCC Rules. These limits are designed to provide reasonable protection against harmful interference when the equipment is operated in a commercial environment. This equipment generates, uses, and can radiate radio frequency energy and, if not installed and used in accordance with the instruction manual, may cause harmful interference to radio communications. Operation of this equipment in a residential area is likely to cause harmful interference in which case the user will be required to correct the interference at his own expense.

9.5 ICES-003 Compliance Statement

This Class A digital apparatus complies with Canadian ICES-003.

Cet appareil numérique de la classe A est conforme à la norme NMB-003 du Canada.



Company Headquarters &
Production Site

E+E Elektronik Ges.m.b.H.
Langwiesen 7
4209 Engerwitzdorf | Austria
T +43 7235 605-0
F +43 7235 605-8
info@epluse.com
www.epluse.com

Subsidiaries

E+E Sensor Technology (Shanghai) Co., Ltd.
T +86 21 6117 6129
info@epluse.cn

E+E Elektronik France SARL
T +33 4 74 72 35 82
info.fr@epluse.com

E+E Elektronik Deutschland GmbH
T +49 6171 69411-0
info.de@epluse.com

E+E Elektronik India Private Limited
T +91 990 440 5400
info.in@epluse.com

E+E Elektronik Italia S.r.l.
T +39 02 2707 86 36
info.it@epluse.com

E+E Elektronik Korea Ltd.
T +82 31 732 6050
info.kr@epluse.com

E+E Elektronik Corporation
T +1 847 490 0520
info.us@epluse.com



—
your partner
in sensor
technology.