







# Electrodes for measuring moisture content of wood and buildings with the T2000 S



Different designs of passive electrodes can be used with the T2000 S to determine moisture content of wood and moisture in mineral, porous materials such as roughcast or screed.

Below you will find all the electrodes in the T2000 programme. The minimum, maximum, average and "hold" values can be displayed with these electrodes in addition to the real time values when measuring with the T2000 (only T2000 S).

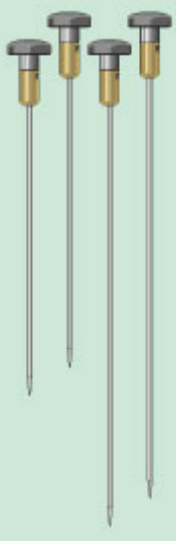

	<b>Electrodes for measuring moisture content of wood</b>
	<b>Electrodes for measuring moisture content of buildings</b>

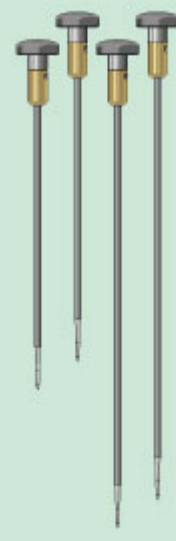

	<b>TS 4/200 and TS 4/300 round electrodes</b>	
	<p>Very thin insertion electrodes (uninsulated, <math>\varnothing</math> 2 mm) for moisture measurement in building and insulating materials through joints or cross joints.</p> <p>Available in lengths 200 mm (TS 4/200) and 300 mm (TS 4/300).</p>	

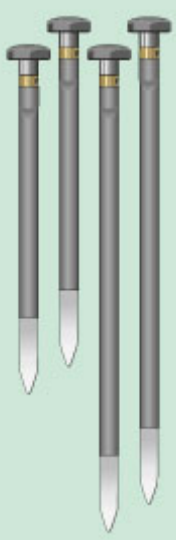

	<b>TS 8/200 and TS 8/300 round electrodes</b>	
	<p>Uninsulated insertion electrodes (<math>\varnothing</math> 4 mm) for measuring moisture on loose mounds such as wood wool or shavings.</p> <p>Available in lengths 200 mm (TS 8/200) and 300 mm (TS 8/300).</p>	



	<b>TS 12/200 and TS 12/300 round electrodes</b>	
	<p>Insulated electrodes (<math>\varnothing</math> 4 mm) for specific moisture measurement in concealed component levels where the electrode shaft needs to be insulated. Absence of insulation would falsify the measuring result. The most frequent use is the determination of moisture distribution of multilayered wall or ceiling structures such as floating screeds, multilayered walls, wooden beam ceilings, hot roofs etc.</p> <p>Available in lengths 200 mm (TS 12/200) and 300 mm (TS 12/300).</p>	

▲ TO THE TOP



	<b>TS 16/200 and TS 16/300 flat electrodes</b>	
	<p>The area of application corresponds to the area of application of the insulated round electrodes TS 12/200 and TS 12/300. The advantage of the flat electrodes (1 mm flat) is that there are no holes in the surface and the electrodes can be inserted through the edging strip after removing the base.</p> <p>Available in the lengths 200 mm (TS 16/200) and 300 mm (TS 16/300).</p>	



	<b>TS 20/110 brush electrode</b>	
	<p>With 110 mm long brush head (<math>\varnothing</math> 7 mm) and insulated shaft. The area of application is the specific measurement of moisture in a homogeneous building material without using a contact mass. The connection to the goods to be measured is made by the brush head.</p>	

	<b>Layer depth electrodes TS 24/250</b>		
	<p>The area of application is the specific layer moisture measurement in homogeneous building materials using the contact mass. The material humidity can be determined according to the length up to a maximum depth of approx. 250 mm. The electrode is made up of the electrode tube and the electrode rod. The electrode tubes (ø 8 mm) are insulated and equipped with a depth scale so that the measured value can be measured at the desired measuring depth.</p>		

	<b>TS 50 insertion electrodes</b>		
	<p>The two-part insertion electrode TS 50 enables the variable distance when positioning the electrode tips. The area of application is the measurement of moisture in hard building materials such as concrete or screeds. The two hexagon union nuts also allow replacement of the following available electrode tips:</p> <ul style="list-style-type: none"> <li>- 20 mm (max. penetration depth 14 mm)</li> <li>- 30 mm (max. penetration depth 24 mm)</li> <li>- 40 mm (max. penetration depth 34 mm)</li> <li>- 60 mm (max. penetration depth 54 mm)</li> </ul>		

▲ TO THE TOP

	<b>TS 60 hand electrode</b>		
	<p>Unbreakable plastic handle with two hexagon union nuts in which electrode tips of the following lengths can be inserted.</p> <ul style="list-style-type: none"> <li>- 20 mm (max. penetration depth 14 mm)</li> <li>- 30 mm (max. penetration depth 24 mm)</li> <li>- 40 mm (max. penetration depth 34 mm)</li> <li>- 60 mm (max. penetration depth 54 mm)</li> </ul> <p>Areas of application are measurement of moisture in cut timber or wooden board materials (e.g. chipboard or fibre boards) and measurement of moisture in soft building materials such as plaster or roughcast mortar.</p>		

	<b>TS 70 ram electrode</b>		
	<p>With moving hammer handle for precision zone and depth measurement especially in woods with different moisture distribution, e.g. liquid nests using Teflon-insulated electrode tips.</p> <p>These are available in lengths of 45 and 60 mm.</p>		